

# Data transport over leaky feeder systems using Internet-Protocol-enabled land mobile radios

by R. Jacksha and C. Sunderman

**Abstract** ■ Mine monitoring through various sensors is a vital component of successful miner safety and health programs. Data from environmental, geotechnical, infrastructure and other types of sensors are increasingly used to discover and mitigate health and safety concerns in underground mines. In many smaller underground mines, as well as in the new development headings of larger underground mines, leaky feeder communication systems may be the only available means to transport crucial monitoring data. In addition, data transport is increasingly being delivered using Internet Protocol (IP), while older forms of serial communication are being retired. This paper presents the selection, configuration and testing methodologies employed by researchers from the U.S. National Institute for Occupational Safety and Health (NIOSH) to integrate commercially available land mobile data radios into an existing leaky feeder communication system to provide IP data transport.

*Mining Engineering*, 2018, Vol. 70, No. 12, pp. 44-47.

Official publication of the Society for Mining, Metallurgy & Exploration Inc.

<https://doi.org/10.19150/me.8644>

## Introduction

To enhance the health and safety of their mining workforce, mine owners and operators are increasingly installing environmental monitoring and control systems in underground mines. Real-time, mine-wide monitoring is becoming a reality with the implementation of the Industrial Internet of Things (IIoT) into the underground mining industry (Zhou et al., 2017). However, not all underground mines, especially smaller mines and new development

headings in larger mines, have the information technology infrastructure in place to handle the data transport requirements for the newer Internet Protocol (IP)-based technologies that are part of IIoT.

This was the case with a mine in the Western United States. It lacked the infrastructure to perform critical monitoring in remote headings. Therefore, the mine partnered with the U.S. National Institute for Occupational Safety and Health's (NIOSH) Spokane Mining Research Division (SMRD) to develop and evaluate a cost-effective solution for the real-time monitoring of geotechnical conditions in relatively remote sections of the mine. This paper describes SMRD's solution to leverage the mine's existing leaky feeder communications system to achieve IP data transport using commercially available land mobile data radios (NIOSH, 2013; Forooshani et al., 2013; Novak, Snyder and Kohler, 2010; Yarkan et al., 2009). The solution, fully evaluated in laboratory and mine environments, requires no modifications to the existing system, is economical, simple to implement,

and reliable. It also allows for transition to higher-bandwidth IT networks, such as fiber optic or WiFi, should they become available.

## Data radio selection

The primary selection criteria for the data radios were network data format, modulation type and radio channel spacing.

The network data format decided upon was IP. This format allowed for straightforward integration between the IP-enabled data acquisition system located in a remote heading and the network switch located in the control room. It also eliminated the added complexity of additional network hardware such as Ethernet to Serial converters. IP additionally provides a direct path to integration into higher-bandwidth networks, such as fiber optic or WiFi, should they become available.

Frequency-shift keying (FSK) was determined to be the best choice for the modulation type, which needed to be compatible with line amplifiers used in leaky feeder systems and could occupy no more than 12.5 kHz of channel

R. Jacksha and C. Sunderman are electronics technician and electrical engineer, respectively, at CDC NIOSH, Spokane, WA, USA. Paper number TP-18-009. Original manuscript submitted March 2018. Revised manuscript accepted for publication August 2018. Discussion of this peer-reviewed and approved paper is invited and must be submitted to SME Publications by Mar. 31, 2019.

bandwidth. Traditionally, leaky feeder radios have employed frequency modulation (FM) and FSK for voice and data signals, respectively. Following land mobile radio (LMR) industry trends to increase channel bandwidth, modern leaky feeder systems have begun to adopt more spectrally efficient, yet more complex, modulation types for both voice and data signals. These modulation types include amplitude phase shift keying (APSK), quadrature amplitude modulation (QAM) and quadrature phase shift keying (QPSK or  $\pi/4$  DQPSK) (Frenzel, 2012; Tait Communications, 2012). The tradeoff between FSK and these other modulation types is that these other modulations typically require enhanced linearity and noise performance for system components such as amplifiers and filters. To limit the effect of amplifier nonlinearity on bit error rate, it was decided to avoid any modulation type using amplitude modulation, such as APSK or QAM. Higher bit error rates could result in significant reductions of data transfer rates.

Channel frequencies and uplink/downlink channel spacing for the transmit (Tx) and receive (Rx) signals in many leaky feeder systems are noncompliant with the LMR standards. As such, the radios needed to be capable of operating using nonstandard channel allocations.

One commercially available data radio was found to meet the desired criteria: the Viper SC+ Intelligent IP Router for Licensed Spectrum from CalAmp (Irvine, CA) (CalAmp, 2018). The Viper SC+ data radio operates as either an Ethernet-capable multipoint or bridge router, is available in both very-high frequency (VHF) and ultra-high frequency (UHF) versions, uses FSK modulation, and can be programmed to operate in a 12.5 kHz channel bandwidth at a data rate of 32 kbps. The Viper SC+ can also be programmed to transmit and receive with the nonstandard downlink/uplink channel range and separation used by some leaky feeder systems. The radio is available in a version with separate Tx and Rx ports, eliminating the added complexity and cost of cavity filters (duplexers) at a leaky feeder system's headend. The cost of the Viper SC+ was about 50 percent more than a typical leaky feeder handset. Figure 1 shows a CalAmp Viper SC+ data radio.

## Radio signal mapping

Research has shown that radio frequency (RF) signal propagation in underground mines differs significantly from that on the surface (Emslie, Lagace and Strong, 1975; Zhou et al., 2015; Jacksha and Zhou, 2016). With this in mind, it was decided to carry out RF signal mapping in areas of the mine where remote data radios could possibly be installed. Understanding the general RF environment was imperative to the design of protocols for successful laboratory evaluation and testing of a possible solution.

RF signal mapping was performed by measuring the leaky feeder system's RF pilot tone signal level on a handheld spectrum analyzer in the drifts, cuts, and stopes that were under consideration for remote radio placement. Measurements were also performed near potential sources of electromagnetic interference, such as power centers, booster fans and variable frequency drives. The RF signal level data revealed that the pilot tone measured no less than -75 dBm within 10 m (33 ft) of a leaky feeder cable in the areas of interest. The pilot tone being 10 dB greater in amplitude than

**Figure 1**  
CalAmp Viper SC+ data radio.



**Figure 2**  
Measuring RF signal level.



other leaky feeder channels translated to a lowest probable signal strength of -85 dBm. Potential electromagnetic interference was not an issue in the leaky feeder's channels of operation. Figure 2 shows a NIOSH engineer measuring RF signal level.

## Laboratory evaluation and testing

The development of a simulated laboratory leaky feeder system served two important purposes. First, it allowed for evaluation and testing of different radio configurations to ensure optimal performance when implemented into a mine setting. Second, it provided a means to troubleshoot any possible unforeseen system issues without traveling to the mine. Since leaky feeder systems operate in Federal Communications Commission (FCC) licensed bands, a simulated leaky feeder system for use in the laboratory had to be designed to prevent illicit radiated emissions. This issue was addressed by using coaxial cables and inline attenuators between the radios to induce signal distribution loss. The resultant simulated leaky feeder system design was made up of six sections — a headend data radio and server, remote data radios, induced

# Technical Papers

distribution signal path loss via attenuators, a broadband noise generator and a system monitor. An overall block diagram of the simulated leaky feeder system is shown in Fig. 3, and Fig. 4 shows a picture of the system in use.

Based on data from the radio signal mapping and the requirement to occupy no more than 12.5 kHz of channel bandwidth, the radios were configured to operate using 16 FSK modulation. This modulation rate results in an Rx sensitivity of -95 dBm, 10 dB below the -85 dBm minimum signal level measured in the mine. The transmit level of the radios was set to 1 W, and clear channel assessment (CCA) was set to be performed prior to transmit. CCA ensures that the radios will not transmit if the channel is currently being used.

For initial data transfer rate assessment, the values of the AT1, AT2, AT3 and AT4 attenuators (Fig. 3) were selected so the signal level at each radio's Rx port would be -65 dBm — well above the radios' specified receiver sensitivity. Due to the high data compression algorithms employed by the radios, typical bandwidth benchmarking tools, such as IPerf or NetStress, would not provide accurate results. For this reason, the simple methods of timing the transfer

of a 1-Mbit file of randomly generated data and ping tests were used to assess data transfer rates. Data transfer tests resulted in measured rates averaging 28 kbps. Taking into account the Ethernet TCP/IP packet overhead, this data rate corresponded to the 32 kbps specified performance of the radios (CalAmp, 2018). Typical ping times averaged 350 ms.

With baseline performance data transfer rates and ping times established, the values of the AT1, AT2, AT3 and AT4 attenuators were adjusted so that the signal level at the radios' Rx port was -90 dBm, 5 dB above the specified receiver sensitivity. Ping times were again measured and remained around 350 ms. The values of the AT3 and AT4 attenuators were then increased in 1-dB increments until the signal level at the radios was -96 dBm, at which point ping requests timed out. This measured receiver sensitivity corresponded closely to the radios' specified receiver performance when using a 16 FSK modulation rate (CalAmp, 2018).

To evaluate noise immunity, the values of AT1, AT2, AT3 and AT4 were adjusted so that the signal level at the radios' Rx port was -80 dBm. The filters, FL2 and FL3, were tuned to the center of the uplink and downlink frequencies, respectively. The purpose of the filters was to allow injection of noise into each individual uplink and downlink signal path while eliminating the potential of the injected noise cross-coupling into the alternate signal path. A repetitive ping cycle was started and the noise source level was increased while being monitored on the system's spectrum analyzer for one or the other signal path. For both signal paths, when the noise level approached -83 dBm, the ping requests timed out. While noise immunity was not specified, this test indicated the radios had a reasonable immunity to noise.

**Figure 3**  
Block diagram of a simulated leaky feeder system with monitoring.

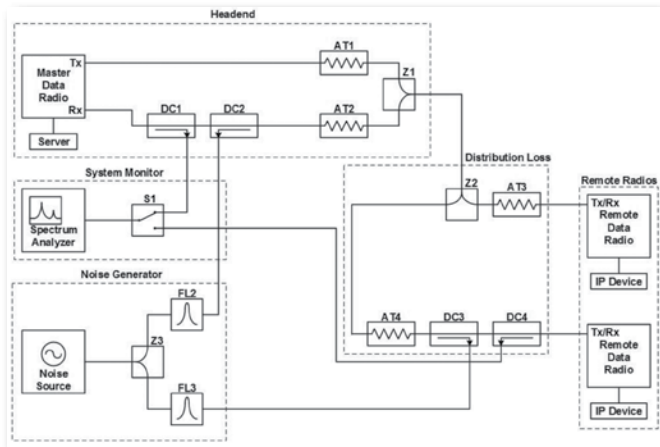

## In-mine implementation

With the radios' configuration defined and laboratory performance evaluated, in-mine implementation of the solution proceeded. The initial data transport solution specified a master data radio to be installed in the leaky feeder head-end and one data radio to be installed at a remote data logger location. One additional data radio was to be installed at a future planned second data logger location.

Installation of the master radio in the headend was straightforward. The radio's Tx and Rx ports were connected to the leaky feeder headend, and transmit signal power

**Figure 4**  
Simulated leaky feeder system.

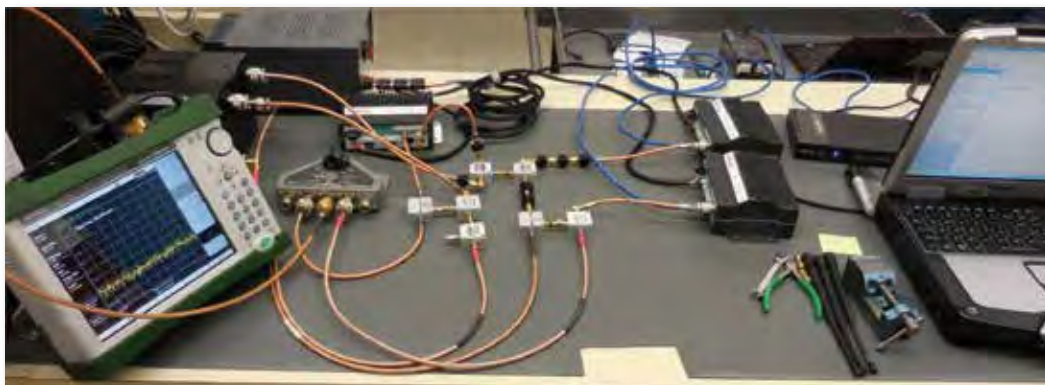

level and channel frequency were verified. Connection of the master data radio to the mine's IT network was delayed until the wireless link between it and the remote data radio could be evaluated.

The remote radio installation entailed mounting the enclosure housing the radio, power supply and data logger on the rib and connecting electrical power. The antenna was mounted to a roof bolt using a magnetic mount and connected to the radio by means of a 4.5-m (15-ft) section of RG-58 coaxial cable. The remote radio's channel frequency allocation was then verified.

With the headend and remote data radios installed, a series of ping tests were performed to evaluate wireless link performance. As in the laboratory evaluation, ping times averaged 350 ms. Figure 5 shows a NIOSH engineer evaluating ping times using a laptop connected to the remote radio.

Once the wireless link performance was verified, the master radio was connected to the mine's IT network via a network switch installed in the leaky feeder headend. To evaluate data transfer, the remote data logger was temporarily configured to accumulate random data, and software installed on a server in the mine's office was configured to upload from the remote logger on a periodic schedule. The scheduled data upload amounted to fewer than 200 bytes, which was typical for the monitoring to be performed.

During the data transfer evaluation, it was noted that data from the remote logger were not being promptly transferred and could take more than 10 min to arrive at the mine's server. A thorough investigation of this issue revealed that the master radio connected to the mine's network was transferring megabytes of network traffic to the remote radio occupying all the available data bandwidth of the radios. To resolve this, the network switch was reconfigured to only allow network traffic specific to the data radios' subnet to be available to the master radio. With this solution implemented, data transfer from the remote data logger to the server occurred within a few hundred milliseconds.

The remote data logger was then reconfigured to acquire actual monitoring data, and the system was made operational.

## Summary

NIOSH researchers developed a solution to transport vital health- and safety-related mine monitoring data over a leaky feeder communications system using commercially available land mobile data radios. In areas of mines with no traditional means of data transport, it was shown that data transmission over leaky feeder using IP-enabled data radios provides a reliable and easily implemented data transport mechanism for lower data rate mine monitoring systems. With careful radio selection and configuration, an adequate leaky feeder signal level, and a properly configured IT network, the solution is, for the most part, "plug-and-play." ■

## Acknowledgments

The authors wish to acknowledge Tom Faulkner of Industrial Communications for sharing his expertise on wireless data transport as well as his guidance in the selection of the Internet Protocol data radios. The authors also wish to acknowledge Andy Powanda of Becker Wholesale Mine Supply for sharing his technical expertise on Becker Varis' Smart Com Leaky Feeder systems.

## Figure 5

Evaluating wireless link performance.



## Disclaimer

The findings and conclusions in this paper are those of the authors and do not necessarily represent the official position of the National Institute for Occupational Safety and Health, Centers for Disease Control and Prevention. Mention of any company or product does not constitute endorsement NIOSH.

## References

- CalAmp, 2018, "CalAmp Viper SC+ | Intelligent IP Router for Licensed Spectrum," Accessed March 12, 2018, <http://help.calamp.com/resources/hardware-specsheets/vipersclusdatasheet.pdf>
- Emslie, A., Lagace, R., and Strong, P., 1975, "Theory of the propagation of UHF radio waves in coal mine tunnels," *IEEE Transactions on Antennas and Propagation*, Vol. 23, pp. 192-205, <https://doi.org/10.1109/tap.1975.1141041>.
- Forooshani, A.E., Bashir, S., Michelson, D.G., and Noghianian, S., 2013, "A survey of wireless communications and propagation modeling in underground mines," *IEEE Communications Surveys & Tutorials*, Vol. 15, No. 4, pp.1524-1545, <https://doi.org/10.1109/surv.2013.031413.00130>.
- Frenzel, L., 2012, "Understanding Modern Digital Modulation Techniques," accessed Aug. 15, 2014, <http://electronicsdesign.com/communications/understanding-modern-digital-modulationtechniques>
- Jacksha, R., and Zhou, C., 2016, "Measurement of RF propagation around corners in underground mines and tunnels," *Transactions of Society for Mining, Metallurgy & Exploration*, Vol. 340, No. 1, pp. 30-37, <https://doi.org/10.19150/trans.7324>.
- National Institute for Occupational Safety and Health (NIOSH), 2013, "Basic Tutorial on Wireless Communication and Electronic Tracking: Technology Overview," <https://www.cdc.gov/niosh/mining/content/emergencymanagementandresponse/commtracking/commtrackingtutorial1.html>.
- Novak, T., Snyder, D.P., and Kohler, J.L., 2010, "Postaccident mine communications and tracking systems," *IEEE Transactions on Industry Applications*, Vol. 46, No. 2, pp.712-719, <https://doi.org/10.1109/tia.2010.2040059>.
- Tait Communications, 2012, "Guide to Digital Radio Standards for Utilities—An introduction to Digital Radios and Related Technology Platforms," Accessed March 12, 2018, [http://go.taitradio.com/rs/dataratitaitradio/images/Tait\\_Guide\\_percent20to\\_percent20Digital\\_percent20Radio\\_percent20Standards\\_percent20for\\_percent20Utilities\\_V1.pdf](http://go.taitradio.com/rs/dataratitaitradio/images/Tait_Guide_percent20to_percent20Digital_percent20Radio_percent20Standards_percent20for_percent20Utilities_V1.pdf)
- Yarkan, S., Guzelgoz, S., Arslan, H., and Murphy, R.R., 2009, "Underground mine communications: A survey," *IEEE Communications Surveys & Tutorials*, Vol. 11, No. 3, pp. 125-142, <https://doi.org/10.1109/surv.2009.090309>.
- Zhou, C., Damiano, N., Whisner, B., and Reyes, M., 2017, "Industrial Internet of Things (IIoT) Applications in Underground Coal Mines," 2017 SME Annual Conference & Expo, Society for Mining, Metallurgy & Exploration, Feb. 19-22, 2017, Denver, CO.
- Zhou, C., Plass, T., Jacksha, R., and Waynert, J.A., 2015, "RF propagation in mines and tunnels: Extensive measurements for vertically, horizontally, and cross-polarized signals in mines and tunnels," *IEEE Antennas and Propagation Magazine*, Vol. 57, No. 4, pp. 88-102, <https://doi.org/10.1109/map.2015.2453881>.