



Safety In Mines Research Advisory Committee

Facilitating safety and health research in the South African mining industry

DIESEL PARTICULATE EMISSIONS IN THE SOUTH AFRICAN MINING INDUSTRY

Willem C. A. van Niekerk PhD QEP (USA)
Dricky Simpson BSc, NHD (Medical Technology and Quality Assurance)
Marlene H. Fourie PhD (Medical Sciences)
Greta Mouton BA (Social Science)

SIMRAC Project Support Services
June 2002

SIM 020602

Executive Summary

Exhaust fumes of diesel driven vehicles are a complex mixture of noxious gases and diesel particulate matter (DPM). In 1988 the National Institute for Occupational Safety and Health (NIOSH) recommended that diesel exhaust emissions be regarded as a “potential occupational carcinogen”, and stated that reductions in workplace exposure would reduce cancer risks. The US Environmental Protection Agency (USEPA) regards DPM amongst the top twenty air pollutants of concern for environmental exposure. Exposure in the mining industry is of particular concern because sometimes air concentrations are much higher than environmental levels, even exceeding concentrations as high as 2 mg/m^3 , which is a thousand times higher than a typical environmental level. In addition, inhalation exposure is not to DPM in isolation, but includes other fine and ultra fine particles resulting from normal mining activities, as well as polynuclear aromatic hydrocarbons (PAHs) that adsorb onto the particulates. These co-exposures may represent a serious health risk.

Some European countries (Germany and Switzerland), as well as Canada and the United States, have adopted regulations that limit the exposure levels of diesel particulate matter in the workplace. However, it appears that controversy still exists regarding the compound to be measured, e.g. elemental carbon, organic carbon, or total carbon. In the United Kingdom there is at present no regulatory limits for DPM. British Columbia, New Brunswick, Quebec and Ontario have adopted a level for respirable combustible dust (RCD) to represent exposure to diesel particulates. The complexity of the chemical and physical composition of diesel exhaust emissions make the assessment of exposure and health risk a challenging task.

The South African mining industry shares the global concern regarding occupational exposure to diesel particulate matter and its associated health effects, but at present there is no occupational exposure limit (OEL) or other guidelines regarding DPM in the workplace. A primary concern about diesel particulates in South African mines is that levels of exposure have never been quantified properly. Methods used in this endeavour have produced results that were not reproducible, and whatever was measured could not be unambiguously related to diesel particulates. Therefore, the level of health risk to workers associated with exposure to diesel particulates is not known and can therefore not be managed effectively.

In addition to this problem of quantification of exposure to particulates, there are also concerns about potential exposure to polynuclear aromatic hydrocarbons (PAHs), which are common products of incomplete combustion and are known to adsorb readily onto a carbon substrate. The extent to which workers are exposed to PAHs adsorbed onto diesel particulates is not known.

A large volume of scientific information is available in the open literature on the toxicology and health effects associated with inhalation of diesel particulates. It has been the intention of this study to present a concise review of the available publications with the aim of highlighting the status of knowledge and understanding in the field, to form a basis for decision-making about control of occupational exposure and institution of regulations in this regard.

Assessment of sampling and analysis methods that are currently in use to quantify exposure to diesel particulates was identified as an essential step early in the study. The automotive industry generally uses a gravimetric method to quantify particulate emissions. However, it is difficult to quantify particulate emissions at levels in workplace air using a conventional gravimetric balance because the amount of particulates collected on filter samples for assessment of occupational exposure is very small. A primary objective in this study has been to identify the most appropriate sampling and analytical methods and to validate the procedures. Occupational exposure surveys in selected mines were integrated with this assessment process, to establish current levels of exposure to diesel particulates. The primary outputs of the study were therefore to establish an appropriate sampling and analytical technique and to assess current levels of exposure to diesel particulates in South African mines.

Based on these findings, recommendations were to be made with regard to the need for the implementation of exposure control measures.

Three candidate mines were identified for testing of the sampling and analytical techniques. A pilot study was conducted in a coalmine, after which more comprehensive studies for quantification of exposure to diesel particulates and PAHs were done in one coalmine and one hard rock goldmine. Some measurements in another goldmine and in two platinum mines were later added to the programme.

Three types of methods were used to determine diesel particulate matter:

- A Rupprecht and Patashnick (R&P) Series 5400 Ambient Carbon Particulate Monitor that has the capability of direct sampling was used for quantification of elemental carbon associated with diesel particulate matter in ambient air.
- A laboratory-based Horiba Mexa 1370PM Super Low Mass PM Analyser was used to analyse diesel particulate matter captured on filters fitted to personal samplers of the type most commonly used to collect dust and other particulate matter in mines.
- A size selective sampler was used to differentiate between elemental carbon associated with diesel emissions and carbon particles from other sources, e.g. coal dust present in coalmines.

Exposure to PAHs was shown to be insignificant. The investigation confirmed that determination of elemental carbon was the preferred method for quantification of exposure to diesel particulate emissions. It was clear from the results of personal sampling using the Horiba Mexa 1370PM instrument for quantification that exposure in some of the mines exceed the international guidelines significantly. The validity of the Horiba measurements was confirmed by comparison of duplicate samples with analyses conducted by the Health and Safety Executive (HSE) in the UK. Furthermore, good agreement in readings was obtained between the Horiba instrument and the R&P direct-reading analyser, which provided additional confidence in the analyses. Therefore, for the first time, it has now been shown that exposures in some of the South African mines are high, at such levels that health effects associated with diesel particulates may occur. These findings indicate the need for the assessment and possible introduction of measures to reduce emissions and exposure, and the requirement for introducing regulations for the control of exposure to diesel exhaust emissions in South African mines.

Acknowledgements

The authors wish to express their gratitude for the assistance, valuable knowledge and experience of many specialists and organisations. The project could not have been successful without their support.

- Horiba Europe GmbH, who provided training in the operation of the MEXA-1370PM Super Low Mass PM Analyser and made the instrument available to SIMRAC on a loan basis. In particular, the following persons should be mentioned: Miro Janda, Horst Moosbauer and Markus Bode.
- Rupprecht and Patashnick Co., Inc. Albany, USA., who arranged a training course on the operation of the R & P Series 5400 Ambient Carbon Particulate Monitor at short notice, and made the instrument available free of charge for an unlimited time for use in the project. In particular, the following persons should be mentioned: Erich Rupprecht, Robert C. Anderson and Deborah Bowe.
- Mike Turnbull of S.I. Analytics (Pty) Ltd South Africa, who made all the arrangements with Rupprecht and Patashnick.
- Without the assistance of Johan Beukes of Health and Occupational Hygiene Laboratory CC it would not have been possible to achieve the same level of success in the project. His knowledge and experience was indispensable;
- Hans Strydom and Gerhard Swanepoel of Afrox South Africa, who supplied the gases for both instruments and kindly made available the cylinder gas regulators at no charge.
- Johan Graebe of SKC Sampling Technologies, who supplied sampling cassette holders and a GS cyclone free of charge.
- The Champion Mines that were involved in the project, particularly staff in the Ventilation and Hygiene Offices. Without their assistance the project would not have been possible.
- Vijay Nundlall of the Department of Minerals and Energy for his collaboration in the project.

Table of contents

1	Introduction	1
1.1	General context	1
1.2	Research problem statement	1
1.3	Objectives and aims of the study	1
1.4	Research design.....	2
1.5	Deployment of the study	2
2	Literature evaluation: toxicity of diesel particulate emissions.....	3
2.1	Emissions from mining vehicles: an overview.....	3
2.1.1	<i>Mine vehicles and pollution</i>	3
2.1.2	<i>Some basic principles</i>	3
2.2	Characteristics and biological significance of particulates.....	3
2.3	Animal studies.....	4
2.4	Human studies	5
2.5	Concerns about polynuclear aromatic hydrocarbons	5
3	The regulatory position	7
3.1	Diesel particulate matter.....	7
3.2	Polynuclear aromatic hydrocarbons	9
4	Overview of current sampling and analytical methods and instrumentation	10
4.1	Sampling and analysis methods for diesel particulate matter	10
4.2	Sampling and analysis methods for PAH.....	11
4.3	Demonstration of commercial instrumentation.....	11
4.3.1	<i>Horiba Mexa-1370PM Analyser</i>	11
4.3.2	<i>Rupprecht and Patashnick Series 5400 Ambient Carbon Particulate Monitor</i>	13
4.3.3	<i>Sampling cassettes</i>	14
5	Scope and design of field sampling	15
6	Materials and methods of the study	16
6.1	Sampling strategy	16
6.2	Sampling methods	16
6.2.1	<i>R&P Series 5400 Ambient Carbon Monitor</i>	16
6.2.2	<i>Personal sampling</i>	16
6.2.3	<i>PAH samples</i>	17
6.2.4	<i>Summary of samples</i>	17
6.3	Analytical methods.....	18
6.3.1	<i>Quantification of elemental carbon with the Horiba Mexa PM Analyser</i>	18
6.3.2	<i>Direct-reading of elemental carbon with the R&P Series 5400 Ambient Carbon Monitor</i>	18
6.3.3	<i>Quantification of polynuclear aromatic hydrocarbons</i>	18
6.4	Statistical methods.....	19
7	Analytical results for elemental carbon	19
7.1	Colliery A	19
7.1.1	<i>Site conditions</i>	19
7.1.2	<i>Error messages and limitations of the R&P Series 5400 instrument</i>	20
7.1.3	<i>Analysis results of direct-reading measurements</i>	20
7.2	Colliery B	21
7.2.1	<i>Site conditions</i>	21
7.2.2	<i>Error messages and limitations of the R&P series 5400</i>	21
7.2.3	<i>Results of direct-reading measurements</i>	21
7.2.4	<i>Personal sampling results</i>	23
7.3	Sampling at Goldmine A.....	23
7.3.1	<i>Site conditions</i>	23
7.3.2	<i>Error messages and limitations of the R&P Series 5400 measurements</i>	24
7.3.3	<i>Direct-reading results</i>	24
7.3.4	<i>Personal sampling results</i>	24
7.4	Additional personal sampling at Goldmine B	25

7.5	Additional personal sampling at Platinum Mine A.....	26
7.5.1	<i>Site conditions</i>	26
7.5.2	<i>Sampling results</i>	26
7.6	Additional personal sampling at Platinum mine B.....	26
7.7	Comparative Data.....	27
7.7.1	<i>Horiba Mexa Analyser versus the UK HSE</i>	27
7.7.2	<i>Horiba Mexa analyser versus the R&P direct-reading monitor</i>	27
7.8	Results of statistical analyses	28
8	Analytical data for polynuclear aromatic hydrocarbons(PAHs)	32
9	Discussion	35
10	References.....	37

List of tables

Table 2.5.1	Relative carcinogenicity of PAH compounds.....	5
Table 2.5.2	The IARC classification for carcinogenicity.....	6
Table 2.5.3	Noncarcinogenic PAH compounds.....	6
Table 3.1.1	Summary of international exposure limits and guidelines pertaining to air concentrations of diesel exhaust particulate matter.....	9
Table 3.2.1	Regulations and guidelines pertaining to PAH compounds.....	9
Table 6.2.4.1	Summary of the direct-reading monitoring activities at the various mines.....	17
Table 6.2.4.2	Summary of the number of samples taken with the Gilair personal sampling device at Colliery B and Goldmine A.	18
Table 7.1.1.1	Conditions at the direct-reading sampling locations in Colliery A.	20
Table 7.1.3.1	Direct-reading sampling results at Colliery A	20
Table 7.2.1.1	Conditions at the direct-reading location in Colliery B.	21
Table 7.2.3.1	Direct-reading results at Colliery B.....	22
Table 7.2.4.1	Elemental carbon concentrations analysed with the Horiba Mexa PM analyser on quartz filters from personal samplers at Colliery B. All results are in $\mu\text{g}/\text{m}^3$	23
Table 7.3.1.1	Conditions at the direct-reading location in Goldmine A.	23
Table 7.3.3.1	Direct-reading results at Goldmine A.	24
Table 7.3.4.1	Elemental carbon concentrations analysed with the Horiba Mexa PM analyser on quartz filters from personal samplers at Goldmine A. All results are in $\mu\text{g}/\text{m}^3$	25
Table 7.4.1	Elemental carbon concentrations analysed with the Horiba Mexa PM Analyser on quartz filters from personal samplers at Goldmine B. All results are in $\mu\text{g}/\text{m}^3$	25
Table 7.5.1.1	Conditions at the sampling location in Platinum Mine A.	26
Table 7.5.2.1	Elemental carbon concentrations analysed with the Horiba Mexa PM analyser on quartz filters from personal samplers at Platinum Mine A. All results in $\mu\text{g}/\text{m}^3$	26
Table 7.6.1	Elemental carbon concentrations analysed with the Horiba Mexa PM analyser on quartz filters from personal samplers at Platinum mine B. All results are in $\mu\text{g}/\text{m}^3$	26
Table 7.7.1.1	Elemental carbon concentrations analysed with the Horiba Mexa PM analyser versus the HSE UK on quartz filters from personal samplers. All results are in $\mu\text{g}/\text{m}^3$	27
Table 7.7.2.1	Elemental carbon concentrations of personal samples analysed with the Horiba Mexa PM analyser versus elemental carbon concentrations of samples analysed with the R&P Monitor at Colliery B. All results are in $\mu\text{g}/\text{m}^3$	27
Table 7.7.2.2	Elemental carbon concentrations of personal samples analysed with the Horiba Mexa PM Analyser versus elemental carbon concentrations of direct-reading samples analysed with the R&P Monitor at Goldmine A. All results are in $\mu\text{g}/\text{m}^3$	28

Table 7.8.1	Bonferroni t-method results for different positions of R&P analyses in different mines.....	30
Table 8.1	Concentrations of PAHs sampled at Colliery B (mg/m ³).....	33
Table 9.1	Compliance of mean concentrations of elemental carbon originating from diesel particulate matter, measured in the various mines, to selected international occupational exposure guidelines for elemental carbon.	36

List of figures

Figure 4.3.1.1:	Horiba MEXA-1379PM elemental carbon analyser (Courtesy of the Engine Measurement Division, Horiba).	12
Figure 4.3.1.2:	Illustration of the analytical process (Courtesy of the Engine Measurement Division, Horiba).	12
Figure 4.3.1.3:	Illustration of the instrument readout of a filter analysis (Courtesy of the Engine Measurement Division, Horiba).	13
Figure 4.3.2.1:	The R&P Series 5400 Ambient Carbon Particulate Monitor in place for sampling and analysis in a goldmine.....	13
Figure 4.3.2.2:	Flow diagram of the R&P Series 5400 Ambient Carbon Particulate Monitor (Courtesy of Rupprecht & Patashnick Co., Inc.).....	14
Figure 4.3.3.1:	SKC-DPM cassette with impactor.....	14
Figure 4.3.3.2:	Personal sampling arrangement for diesel particulate matter according to NIOSH Method 5040.....	15
Figure 7.8.1:	Bland-Altman plot comparing elemental carbon measured with the Horiba Mexa PM analyser with direct reading results from the R&P instrument. All numbers are in µg/m ³	29
Figure 7.8.1:	Bland-Altman plot comparing elemental carbon measured with the Horiba Mexa PM analyser with measurements by the HSE. All numbers are in µg/m ³	31

List of terms and abbreviations

Abbreviations

ACGIH	American Conference of Government Industrial Hygienists
USEPA	United States Environmental Protection Agency
AOEH	Applied Occupational and Environmental Hygiene
XAD-2	A macroporous styrene divinyl benzene polymer, used as substrate in air sampling tubes.
ASE	Accelerated Solvent Extraction
DPM	Diesel particulate matter
DEP	Diesel exhaust particles
EC	Elemental Carbon
GC/MS	Gas chromatography / Mass spectrometry
HSE	Health and safety executive
MSHA	Mine safety and health administration
NIOSH	National Institute for Occupational Safety and Health
NMAM	NIOSH Manual of Analytical Methods
OC	Organic Carbon
OEL	Occupational exposure limit
PAH	Polynuclear aromatic hydrocarbons
PM	Particulate matter
R&P	Rupprecht & Patashnick
RCD	Respirable combustible dust
SANAS	South African National Accreditation System
SIMRAC	Safety in Mines Research Advisory Committee
SSS	Size selective sampling
SOF	Soluble Organic Fractions
TLV	Threshold Limit Value
TC	Total Carbon
UK	United Kingdom
IgE	Immunoglobulin antibodies implicated in allergic reactions.
IgG	Immunoglobulin antibodies released during the normal immune response that are smaller and more penetrative than the larger IgM molecules
RNA	Ribonucleic acid
IMP	Inspection and maintenance programme
VOF	Volatile organic fraction

Terminology

Absorbed	The attachment of a substance to a surface
Adverse	An unexpected or unwanted effect
Aerodynamic diameter	The diameter of a unit density sphere with the same terminal settling velocity as the particle, regardless of its size, shape or density. The terminal settling velocity is the constant velocity at which a particle will settle in air medium when equilibrium is reached between the gravitational force and the sum of the particle's buoyancy and air resistance
Aerodynamic	The flow of air especially around solid bodies
Air velocity	The measurement of the speed of air movement, measured in meters per second
Alveoli]	Sites of gas exchange with blood in the lungs. Alveoli takes on the form of blind pockets at the terminal ends of the bronchial tree
Amberlite® Supelco	The brand name of the resin tubes used for the collection of polynuclear aromatic

	hydrocarbons
Ambient	Pertaining to the surrounding air, as opposed to the undiluted exhaust gas
Asthma	A disease caused by increased responsiveness of the tracheobronchial tree to various stimuli, which results in paroxysmal (sudden, periodic attack) constriction of the bronchial airways.
Atopy	Meaning out of place, is a form of hypersensitivity characterized by familial tendency. It is due to the propensity of the effected individual to produce large amounts of antibodies, which stick to mast cells in the mucosa so that when the antigen is inhaled, histamine is released from the mast cell. It is the condition responsible for asthma and hay fever.
Barometric Pressure	The atmospheric pressure
Bronchial	Also bronchus tube, name applied to tubes into which the windpipe divides, one going to either lung where it distributes throughout the lung, the smallest being the bronchioles
Carbonaceous particles	Particles containing carbon
Carcinogen	A substance that has the potential to cause cancer
Cardiovascular	Pertaining to the heart and blood vessels
Chromatography	The separation of chemical elements on the basis differing physical and chemical characteristics, e.g. size or solubility.
Chronic	A persistent or recurring condition
Coulometric	An analysis or quantification method based on the development of a colour reaction.
Cyclone:	Air movement around the centre of low pressure
Cytochromes	Pigment components of the electron transporting system in the mitochondria, ultimately responsible for the production of energy in the form of adenosine triphosphate (ATP)
Cytoplasm	The cellular fraction contained within the cellular membrane.
Dust	Particles generated by the disintegration of solid materials.
Eimco	A heavy duty vehicle used in the coal mining industry
Emissions	The output of burned remains through an exhaust system
Endothelium	Layer of cells that forms a superficial covering or an internal lining of a body cavity or vessel
Eosinophil	Specific type of white blood cell found in blood.
Epithelium	The cellular layer which forms the epidermis on the skin, covers the inner surface of the bowels, and forms the lining of the ducts and hollow organs
Erythrocytes	Red blood cells
Fibronectin	Fibrous connective tissue protein
Fibrosis	Formation of fibrous or scar tissue, usually due to either infection or deficient blood supply.
Fume	Aerosol of solid particles resulting from condensation of the vapour given off from the heating of metals.
Gas	Substances such as CO in air that are normally in the gaseous state under ambient conditions of temperature and pressure.
Goblet cell	A columnar secretory cell occurring in the epithelium of the respiratory and intestinal tracts. The cell produces the main constituents of mucus
Gravimetric	An analysis or quantification method based on differences in the masses of chemical samples.
Humidity:	Grading of the amount of moisture in the air
Jewelled impactor	An impactor is a sampler of air particles. A jeweled impactor is enclosed in a plastic container that facilitates transport and storage of samples.
Lavage	The name applied to the washing out of an organ like the stomach
Leucocytes	White blood cells
LiCorCom CO ₂ sensor	A specific type of sensor used by Rupprecht and Patashnick in the series 5400 monitor (see sensor)
Loco	A small type of locomotive used in the underground mines to perform various duties
Lymphocytes	A variety of white cells produced in the lymphoid tissues and lymphatic glands of the body
Lysosomal	Of the lysosome, an organelle in the cytoplasm of cells that facilitates the digestion of redundant or damaged cells or cellular components/
Macrophages	A large phagocyte that forms part of the reticuloendothelial system

Mass-spectroscopy	Sorting and identification of molecules according to their mass-charge ratio
Mast-cells	Round or oval cells of the immune system found predominantly in the loose connective tissues
Morphology	The form and structure of organisms
Mucosa	A term for mucous membrane
Nasal mucosal	Of the mucous membrane that lines the nose
Neutrophils	A type of white blood cell or leucocyte
Oedema	An abnormal accumulation of fluid beneath the skin or in the cavities of the body
Oxidation	The process where an oxygen molecule binds to another element
Oxygenase	An enzyme that catalyses a reaction where oxygen is covalently bonded to a substrate.
Parenchyma	Meaning originally all the soft tissue of internal organs except the muscular flesh
Particulate	Minute portion of matter
Peripheral	The outlying parts of the body
Peroxidase	An enzyme that catalyses the reduction of alkyl hydroperoxides with the resultant release of water
Phagocytosis	A process by which the attacks of bacteria upon the living body are repelled and the bacteria destroyed through the activity of the white corpuscles in the blood
Pneumocytes	Alveolar cells.
Polynuclear aromatic hydrocarbons	Hydrocarbons with a structure made up of multiple rings bonded together covalently.
Polycyclic	Made up of many cyclic structures.
Proliferation	Rapid growth or reproduction
Pulmonary oedema	An abnormal accumulation of fluid in the lungs
Receptors	Organs, which may consist of one or a small number of cells, which responds to different forms of external or internal stimuli
Respiration	The exchange of gases between cells and the environment
Respiratory epithelium	Epithelium that covers the inside of the respiratory tract.
Respiratory tract	The airways, starting with the nose and mouth, leading through the pharynx in succession the larynx, the trachea, bronchi, bronchiole and ending in the alveoli of the lung.
Thermo	A prefix implying some relation to heat
Threshold limit	The concentration of a chemical above which adverse health and/or environmental effects may occur
Toxic	Harmful, or deleterious with respect to the effects produced by exposure to a chemical substance
Toxicity	The harmful effects produced by a chemical substance. It is the quality or degree of being poisonous or harmful to human or ecological receptors. It represents the property of a substance to cause any adverse physiological effects on living organisms.
Thrombocytosis	Abnormal increase in the number of platelets in the blood.
Vaporise	Conversion of liquid (or solid) form of matter into its gaseous form
Vapour	The gaseous form of a substance that is normally in the liquid or solid phase at room temperature and pressure
Vascular permeability	Permeability of blood vessels.

1 Introduction

1.1 General context

Diesel exhaust particulates are major air components of inhaled particulate pollution in the industrialised world. Exposure to these and other fine particulate pollution is of great concern since studies indicate a positive association between airborne levels and respiratory illness and mortality.

Exhaust fumes of diesel driven vehicles are a complex mixture of noxious gases and diesel particulate matter (DPM). In 1988 the National Institute for Occupational Safety and Health (NIOSH) recommended that diesel exhaust emissions be regarded as a “potential occupational carcinogen” and stated that reductions in workplace exposure would reduce cancer risks (NIOSH, 1988). The US Environmental Protection Agency (USEPA) regards DPM amongst the top twenty air pollutants of concern for environmental exposure (USEPA, 1993). Exposure in the mining industry is of particular concern because sometimes air concentrations are much higher than environmental levels, even exceeding concentrations as high as 2 mg/m^3 , which is a thousand times higher than a typical environmental level. In addition, inhalation exposure is not to DPM in isolation, but includes other fine and ultra fine particles resulting from normal mining activities, as well as polynuclear aromatic hydrocarbons (PAHs) that adsorb onto the particulates. These co-exposures may represent a serious health risk.

Some European countries (Germany and Switzerland), as well as Canada and the United States, have adopted regulations that limit the exposure levels of diesel particulate matter in the workplace. However, it appears that controversy still exists regarding the compound to be measured, e.g. elemental carbon, organic carbon, or total carbon. In the United Kingdom there is at present no regulatory limits for DPM. British Columbia, New Brunswick, Quebec and Ontario have adopted a level for respirable combustible dust (RCD) to represent exposure to diesel particulates. The complexity of the chemical and physical composition of diesel exhaust emissions makes the assessment of exposure and health risk a challenging task.

The South African mining industry shares the global concern regarding occupational exposure to diesel particulate matter and its associated health effects, but at present there is no occupational exposure limit (OEL) or other guidelines regarding diesel particulate matter in the workplace.

1.2 Research problem statement

A primary concern about diesel particulates in South African mines is that levels of exposure have never been quantified properly. Methods used in this endeavour have produced results that were not reproducible, and whatever was measured could not be unambiguously related to diesel particulates. Therefore, the level of health risk to workers associated with exposure to diesel particulates is not known and can therefore not be managed effectively.

In addition to this problem of quantification of exposure to particulates, there are also concerns about potential exposure to polynuclear aromatic hydrocarbons (PAHs), which are common products of incomplete combustion and are known to adsorb readily onto a carbon substrate. The extent to which mineworkers are exposed to PAHs adsorbed onto diesel particulates is also not known.

1.3 Objectives and aims of the study

A large volume of scientific information is available in the open literature on the toxicology and health effects associated with inhalation of diesel particulates. It is the intention of this study to present a concise review of the available publications with the aim of highlighting the status of

knowledge and understanding in the field, to form a basis for decision-making about control of occupational exposure and institution of regulations in this regard.

Assessment of sampling and analysis methods that are currently in use to quantify exposure to diesel particulates has been identified as an essential step early in the study. The automotive industry generally uses a gravimetric method to quantify particulate emissions. However, it is difficult to quantify particulate emissions at levels in workplace air using a conventional gravimetric balance because the amount of particulates collected on filter samples for assessment of occupational exposure is very small. A primary objective in this study is to identify the most appropriate sampling and analytical methods and to validate the procedures. Occupational exposure surveys in selected mines have to be integrated with this assessment process, to establish current levels of exposure to diesel particulates.

The primary outputs of the study are therefore to establish an appropriate sampling and analytical technique and to assess current levels of exposure to diesel particulates in South African mines. Based on these findings, recommendations have to be made with regard to the need for the implementation of exposure control measures. Sampling and analytical methods for quantification of PAHs in air are well established.

1.4 Research design

The first step would be to review the various sampling and analytical methodologies that are employed in the world, and then to select the most appropriate options for evaluation. Facilities have to be arranged where samples could be analysed.

Three candidate mines have been identified for testing of the selected sampling and analytical techniques. A pilot study will be conducted in a coalmine, after which more comprehensive studies for quantification of exposure to diesel particulates and PAHs will be done in one coalmine and one hard rock goldmine.

Analytical results and findings of the study will be used as a basis for assessment of current levels of exposure to diesel particulates and PAHs in mines and the possibility of introducing emission control measures.

1.5 Deployment of the study

Section 1:	Introduction
Section 2:	Literature evaluation: toxicity of diesel particulate emissions.
Section 3:	The regulatory position
Section 4:	Overview of current sampling and analytical methods and instrumentation
Section 5:	Scope and design of field sampling
Section 6:	Materials and methods of the SIM 020602 study
Section 7:	Analytical results for elemental carbon
Section 8:	Analytical data for polynuclear aromatic hydrocarbons(PAHs)
Section 9:	Discussion
Section 10:	References

2 Literature evaluation: toxicity of diesel particulate emissions

2.1 Emissions from mining vehicles: an overview

2.1.1 Mine vehicles and pollution

In South African collieries, underground vehicles are expected to be mainly diesel-driven tractors, light delivery vehicles (bakkies), buses and eimcos (caterpillars). Locos are almost exclusively used in the hard rock mines. Emissions from a single individual vehicle may not be significant in the overall assessment of mining pollutants, but taking into account the number of vehicles operating in the enclosed environment of the mine, daily emissions have the potential to become a significant health risk factor. There may be big differences in emissions between different vehicles, even between those of the same type, and exposure of employees working in the same areas may therefore differ considerably. Diesel particulate matter as well as other fine and ultra fine particles contribute to the daily exposure of the workers.

2.1.2 Some basic principles

The power to move a vehicle is initiated from burning of fuel in an engine. Pollution from vehicles originates from the formation of by-products of this burning or combustion process and from evaporation of the fuel itself.

Gasoline and diesel are mixtures of hydrocarbons; these are compounds that contain hydrogen and carbon atoms. In the perfect engine, oxygen from the air would convert all the hydrogen in the fuel to water and all of the carbon to carbon dioxide, while the nitrogen in air would remain unaffected. But, in reality, the combustion process cannot be perfect and the vehicle engines emit several types of pollutants. The situation is summarised below (*USEPA, 1993*):

- **Perfect engine combustion**

fuel (hydrocarbons) + air (oxygen and nitrogen) → CO₂ + water + unaffected nitrogen

- **Typical engine combustion**

fuel + air → unburned hydrocarbons + NO_x + CO₂ + CO + water

Chemical compounds in diesel exhaust emissions are therefore a complex mixture of noxious gases and diesel particulate matter, which in turn consists of non-volatile elemental carbon, condensed hydrocarbons, sulphates and trace elements of metallic compounds. The main health concerns associated with gaseous exhaust emissions are the hydrocarbons, nitrogen oxides and carbon monoxide (*NIOSH, 2002*). Under conditions of high pressure and temperature in an engine, nitrogen and oxygen atoms in the air react to form various nitrogen oxides, collectively known as NO_x. Carbon monoxide is a product of incomplete combustion and occurs when carbon in the fuel is partially oxidised rather than fully oxidised to CO₂.

2.2 Characteristics and biological significance of particulates

Particulate matter (PM) is often characterised by aerodynamic size and referred to as PM₁₀, PM₁ or PM_{2.5} where PM₁₀, for example, indicates particles of less than ten micrometers aerodynamic diameter. There is no doubt that traffic plays a major roll in the contribution to particulate matter pollution in urban areas, especially emissions from diesel-powered vehicles. These diesel particulates form a large proportion of the atmospheric fine particle fraction. Diesel exhaust particles consist of individual spherical carbonaceous particles that readily aggregate

into chains and clusters. Polynuclear aromatic hydrocarbons and metals are known to be associated with diesel particulates (*Murphy et al., 1999*).

Compared to gasoline engines, diesel engines produce less carbon monoxide, but give rise to greater amounts of nitrogen oxides and aldehydes, which are particularly prone to cause irritation of the upper respiratory tract (*Parnia et al., 2001*). Although diesel-driven vehicles contribute less than 25 per cent carbon monoxide compared to petrol engines, this advantage appears to be greatly compromised by the amount of particulates and oxides of nitrogen generated by diesel engines. Diesel engines emit up to 100- to 150-times more particulates and up to 2- to 20-times more oxides of nitrogen than petrol-driven engines. Diesel exhaust is therefore one of the major contributors to particulate matter pollution in urban areas, contributing up to 90 per cent of the ultra fine particulate mass in the ambient air of large cities of the world. Over 80 per cent of diesel exhaust particles are between 0.1 and 0.2 μm in diameter and thus remain airborne for long periods of time and when inhaled, they are readily deposited in the lung (*Editorial, 1999*). Such fine and ultra fine particles provide a large surface area for biological reaction; they penetrate deeply into the lungs and locate across the respiratory epithelium.

Other important chemical and physical properties, in addition to size, are the volatility, solubility, chemical composition, morphology, density, electrical charge on the particle and the state of the particulates (solid or solid with liquid adsorbed). These properties are particularly important for the selection of methods for regulation and control of emissions. Mass and size, however, seem to be the most important parameters contributing to the adverse health effects. (*Wahlin et al., 2001*).

Following inhalation and deposition of the ultra fine particulates in the lungs, macrophages in the alveoli rapidly phagocytose the particulates using scavenger-type receptors, and migrate towards the bronchoalveolar junction. Large numbers of ultra fine particulates seem to pose a burden on the macrophage-phagocytose system, thus resulting in an increased number of particles coming into contact with the respiratory epithelium (*Salvi et al., 1999*).

2.3 Animal studies

A number of studies in which experimental animals had been exposed to particulates generated from diesel exhaust were reported in the literature. Guinea pigs and mice exposed to diesel particles demonstrated increased nasal mucosal hyper responsiveness to histamine with enhanced sneezing and increased nasal secretions which are associated with increased vascular permeability, stiffness of lung parenchyma and a reduction in lung volumes and lung compliance. Rodents chronically exposed to diesel particulates showed increased signs of cellular injury, which were followed by increased synthesis and deposition of collagen, producing thickening of the alveolar septa and blood vessels and the development of interstitial fibrosis. Some of the earliest changes of lung toxicity in guinea pigs are damaged capillary endothelial cells and type ii pneumocytes of the alveolar epithelium, alveolar oedema and subsequent cellular inflammatory responses involving neutrophils (*Salvi et al., 1999*). Electron microscopic analysis has demonstrated that the particulate component of diesel exhaust causes alveolar destruction in a concentration and duration-dependent manner (*Nagai et al., 1996*).

Instillation of diesel particles in mice has demonstrated aggravation of allergen-induced airway inflammation, characterised by increased IL-5 levels in broncho-alveolar lavage fluid, increased eosinophilic and lymphocytic infiltration of the lung tissue, along with increased numbers of goblet cells in the bronchial epithelium (*Gavett et al., 1998*). Diesel particles and specifically their carbon core has been shown to have a significant adjuvant effect on the local immune-mediated inflammatory response as well as on the systemic-specific IgE response to allergen; that is, diesel particulates potentiate the immune response to antigens and to allergens (*Takenaka et al., 1995 and Suzuki et al., 1996*).

2.4 Human studies

Reported effects of inhaled diesel particles on the airways of healthy human subjects, after exposure to diesel exhaust particulate for one hour, included increased numbers of alveolar macrophages, T-lymphocytes and neutrophils in the broncho-alveolar lavage fluid, as well as an acute inflammatory response in the peripheral blood and airway tissue. The inflammatory indices involved peripheral blood neutrophilia, thrombocytosis, increased histamine, fibronectin, neutrophils and Blymphocytes in the airway lumen and increased numbers of inflammatory cells in the bronchial tissue, which include neutrophils, lymphocytes and mast cells (*Rudell. et al., 1990*). Instillation of diesel particulates in atopic human subjects resulted in increased IgE mRNA and IgE levels in the nasal lavage, indicating an increased potential for allergic reactions. This has been confirmed by co-administration of the diesel particles with allergens, which produced a 50-fold increase in allergen specific IgE compared to the allergen alone. These results suggest that diesel particles induced a quantitative and a qualitative increase in IgE levels, and can therefore contribute to the enhancement of mucosal allergy (*Fujieda et al., 1998*).

2.5 Concerns about polynuclear aromatic hydrocarbons

Polynuclear aromatic hydrocarbons have quite different toxicities, to the extent that some of them are carcinogenic and others are not. The classification of carcinogens according to the International Agency for Research on Cancer (*IARC, 2002*) was used in this report.

Carcinogenicities relative to the carcinogenicity of benzo[a]pyrene are presented in Table 2.5.1 (*Collins, Brown and Dawson, 1991*).

Table 2.5.1
Relative carcinogenicity of PAH compounds.

Polynuclear aromatic hydrocarbon	Carcinogen classification	Relative carcinogenicity
Dibenzo[a,h]anthracene	2A	1.11
Benzo[a]pyrene	2A	1.0
Anthranthracene	3	0.320
Indeno[1,2,3-cd]pyrene	2B	0.232
Benzo[a]anthracene	2A	0.145
Benzo[b]fluoranthene	2B	0.141
Benzo[k]fluoranthene	2B	0.066
Benzo[j]fluoranthene	2B	0.061
Pyrene	3	0.081
Cyclopenta[cd]pyrene	3	0.023
Benzo[ghi]perylene	3	0.022
Chrysene	3	0.0044
Benzo[e]pyrene	3	0.004

There are more PAHs that are carcinogenic according to the International Agency for Research on Cancer, but Table 2.5.1 represents those that have the highest cancer potency. Table 2.5.2 explains the IARC carcinogen classification system.

Table 2.5.2
The IARC classification for carcinogenicity.

<p>Group 1 <i>Human carcinogen</i> Sufficient evidence of carcinogenicity in humans.</p> <p>Group 2A <i>Probable human carcinogen</i> Limited human data and sufficient animal data. Only limited human data, or only sufficient animal data in the presence of other supporting data.</p> <p>Group 2B <i>Possible human carcinogen</i> Limited human data in the absence of sufficient evidence in animals. Sufficient animal data with inadequate or no human data. Limited animal data with other supporting data, and inadequate or no data in humans.</p> <p>Group 3 <i>Not classifiable</i> Data do not fit into any of the above groups.</p> <p>Group 4 <i>Probably not a human carcinogen</i> Evidence suggests lack of carcinogenicity in humans and animals.</p>

The PAH compounds listed in Table 2.5.3 below have not been demonstrated to be carcinogenic.

Table 2.5.3
Noncarcinogenic PAH compounds.

Polynuclear aromatic hydrocarbons	
Acenaphthalene	Fluoranthene
Acenaphthene	Fluorene
Anthracene	1-Methylchrysene
Benz[a]acridine	3-Methylfluoranthene
Benz[a]fluorene	1-Methylphenanthrene
Benz[b]fluorene	1-Methylnaphthalene
Benz[c]fluorene	3-Methylnaphthalene
Benzo[g,h,i]perylene	Naphthalene
Benzo[c]phenanthrene	Perylene
Benzo[e]pyrene	Phenanthrene
Coronene	Pyrene
Dimethyl naphthalenes	Triphenylene
1,4 Dimethylphenanthrene	

The chemical structures of some of the PAHs are presented in Figure 2.5.1.

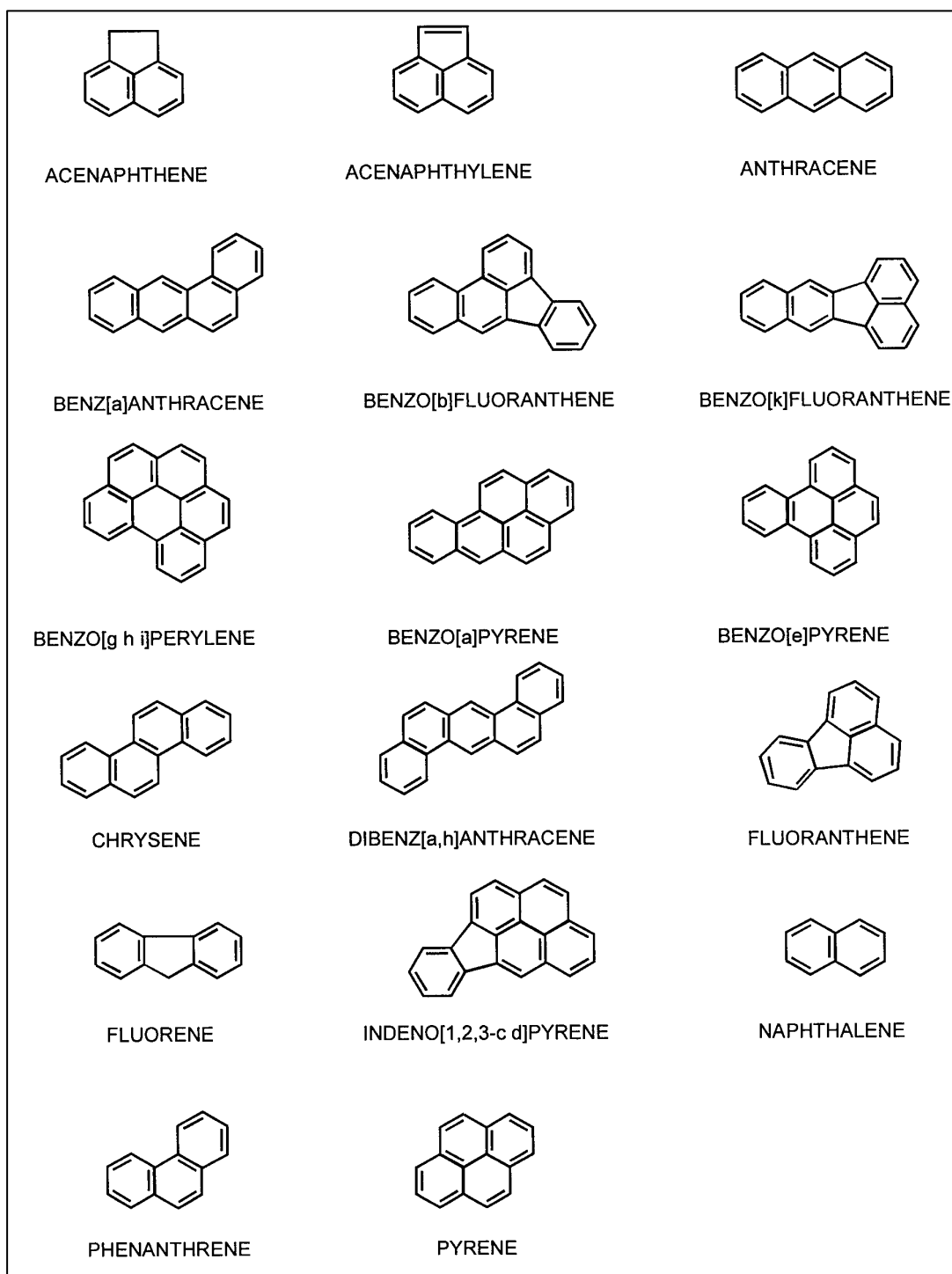

Figure 2.5.1 Configurations of some of the most significant polynuclear aromatic hydrocarbons.

3 The regulatory position

3.1 Diesel particulate matter

As early as 1988 the National Institute for Occupational Safety and Health (NIOSH) issued a report stating that diesel exhaust is a suspected occupational carcinogen (*Guillemin, 1997*). More recently, the US Department of Health and Human Services has classified diesel exhaust emissions as "likely to be carcinogenic" (*NTP, 2002*).

In 1990 the Canadian *ad hoc* Diesel Committee published a guideline suggesting that exposure to diesel particulate matter should be measured using the Respirable Combustible Dust (RCD) method and be limited to 1.5 mg/m³ over a normal eight-hour shift (DEEP, 2001). This exposure limit has thereafter been adopted by most mining provinces in Canada.

In January 2001, the US Mine Safety and Health Administration (MSHA) issued a final ruling for US metal and non-metal mines. In this ruling, MSHA requires that mines meet a limit of exposure of 0.40 mg/m³ within eighteen months after acceptance of the tabled document. Mines would thereafter be expected to reduce exposure in order to meet a 0.16 mg/m³ limit of exposure by January 2006 (NIOSH, 2002). This limit of exposure is based on the measurement of total carbon using the NIOSH 5040 Method (NIOSH, 1998).

The American Conference of Governmental Industrial Hygienists (ACGIH) is the organisation that publishes the well-known Threshold Limit Value (TLV®) guidelines on an annual basis. The ACGIH guidelines do not have any legal standing, but are being used in many parts of the world as legal exposure limits by regulators.

In 1996, the ACGIH published a notice of intended change in which a diesel particulate matter TLV of 0.15 mg/m³ was suggested. In 1998 the ACGIH further reduced this proposed TLV to 0.05 mg/m³. Both of these limits were based on the measurement of total carbon similar to the MSHA rule. In 2001, the ACGIH suggested a limit of 0.02 mg/m³ based on the measurement of elemental carbon only. The NIOSH Method 5040 also measures elemental carbon (DEEP, 2001).

European mines and tunnel construction projects are also subject to diesel particulate matter limits of exposure. In Europe, a method similar to the NIOSH 5040 is being used to measure elemental and organic carbon. Countries have adopted different limits of exposure depending on whether elemental or total carbon is measured for compliance purposes. Until 1996 Germany applied an eight-hour threshold limit value of 200 µg/m³ in the general workplace and for non-coalmines, a limit of 600 µg/m³, measured as total carbon. These exposure limits have subsequently been revised by redefining the analyte to elemental carbon and in 1997 new limits were introduced. These are 300 µg/m³ for elemental carbon in non-coalmines and 100 µg/m³ for other non-coal areas. Exposure in coalmines has not been addressed specifically. In road tunnels in Switzerland the limit of exposure is 0.2 mg/m³ expressed as total carbon (DEEP, 2001). Ambient air concentrations of elemental or total carbon are at present not regulated in the UK.

Table 3.1 reflects a summary of exposure limits that currently apply in various countries.

Table 3.1.1
Summary of international exposure limits and guidelines pertaining to air concentrations of diesel exhaust particulate matter.

Agency / Committee / Regulator	Date submitted	Exposure guideline/limit	Substance measured
Canadian <i>ad hoc</i> Diesel Committee (Currently in effect in most Canadian mining provinces)	1990	1.50 mg/m ³	RCD
MSHA	2001	0.4 - 0.16 mg/m ³	TC
ACGIH	1996	0.15 mg/m ³	TC
ACGIH	1998	0.05 mg/m ³	TC
ACGIH	2001	0.02 mg/m ³	EC
Germany: General occupational environment	1997	0.1 mg/m ³	EC
Germany: Underground non-coal mining	1997	0.3 mg/m ³	EC
Switzerland (road tunnels)	2001	0.2 mg/m ³	DEEP, 2001
United Kingdom	N/A	N/A	N/A
NIOSH	2002	0.16 mg/m ³ to be reached by January 2006	EC
South Africa	N/A	N/A	N/A

ACGIH: American Conference of Governmental Industrial Hygienists.

NIOSH: National Institute for Occupational Safety and Health.

MSHA: Mine Safety and Health Administration.

RCD: Respirable combustible dust.

N/A: Not regulated.

EC: Elemental carbon.

TC: Total carbon.

3.2 Polynuclear aromatic hydrocarbons

The Carcinogen Assessment Group at USEPA has designated many of the PAHs as potential carcinogens. NIOSH has a recommended exposure limit (REL) of 0.1 mg/m³ as a 10-hr time-weighted average (TWA) for coal tar products, which contain several PAHs (NIOSH, 1977). OSHA indirectly limits exposure to PAHs by requiring that occupational exposure to coal tar pitch volatiles not exceed 0.2 mg/m³ as an 8-hr TWA. In another attempt to minimise the risk of workplace exposure to PAHs, OSHA promulgated a permissible exposure limit (PEL) of 0.15 mg/m³ as an 8-hr TWA for coke oven emissions (OSHA, 1978). OSHA also regulates PAHs under the Hazard Communication Standard and as chemical hazards in laboratories.

Table 3.2.1
Regulations and guidelines pertaining to PAH compounds.

Polynuclear aromatic hydrocarbon	Regulating agency	Guideline
Benzo[a]pyrene	OSHA	0.2 mg/m ³ (TWA)
Naphthalene	NIOSH	50 mg/m ³ (TWA) 75 mg/m ³ (STEL)
Naphthalene	ACGIH	52 mg/m ³ (TWA) 79 mg/m ³ (STEL)
Naphthalene	SA DME	50 mg/m ³ (OEL) 75 mg/m ³ (OEL-STEL)

OSHA: US Occupational Safety and Health Administration.

NIOSH: US National Institute of Occupational Safety and Health.

ACGIH: American Conference of Government Industrial Hygienists.

SA DME: South African Department of Minerals and Energy Mine Health and Safety Inspectorate. Proposed Regulations of 7 December 2000.

TWA: Threshold limit value (Time-weighted average): the time-weighted average concentration for a conventional 8-hour workday and a 40-hour workweek, to which it is believed that nearly all workers may be repeatedly exposed, day after day, without adverse effect.

- STEL: Threshold limit value (Short-term exposure limit): a 15-minute TWA exposure, which should not be exceeded at any time during a workday, even if the 8-hour TWA is within the TLV-TWA. Exposures above the TLV-TWA up to the STEL should not be longer than 15 minutes and should not occur more than four times per day. There should be at least 60 minutes between successive exposures in this range.
- OEL: Occupational exposure limit: the time weighted average concentration for a 8 hours per day or 40 hour work week to which nearly all workers may be repeatedly exposed without adverse health effects.
- OEL-STEL: Occupational exposure limit – Short term exposure limit means a 15-minute TWA exposure which should not be exceeded at any time during a workday even if the 8-hour TWA is within the OEL-TWA. Exposures above the OEL-TWA up to the STEL should not be longer than 15 minutes and should not occur more than four times per day. There should be at least 60 minutes between successive exposures in this range.

4 Overview of current sampling and analytical methods and instrumentation

4.1 Sampling and analysis methods for diesel particulate matter

Diesel particulate matter has a mass median diameter of 0.1 μm , with 90 per cent of the particles being < 1.0 μm in diameter. It is composed primarily of organic carbon, elemental carbon, adsorbed and condensed hydrocarbons, and sulphate. The ratio of organic carbon to elemental carbon varies, depending on factors such as fuel type, engine type, duty cycle, engine maintenance, operator habits, use of emission control devices, and oil consumption (Watts et al., 2000).

Three sampling methods are used in underground mines in various parts of the world to collect diesel particulate matter samples for analysis:

- *The respirable combustible dust method (RCD) was developed in Canada to estimate diesel particulates in non-coalmines (DEEP, 2002). RCD is composed of all combustible substances collected on a sample filter including drill oil mist, the soluble fraction of the particulate matter, elemental carbon and other combustible material such as carbonaceous material found in the ore dust.*
- *NIOSH (1998) has developed a sensitive measure of the elemental carbon (EC) portion of diesel particulate matter (Method 5040). The method also determines organic carbon (OC) and by summation of the EC and OC the total carbon can be determined. In general, elemental carbon accounts for about 50 per cent of the mass of diesel particulate matter, but this varies as discussed above. Since EC is a product of combustion and is composed of inert graphitic carbon it is a specific marker of diesel exhaust aerosol where other combustion aerosols are not present. The OC portion, on the other hand, is subject to interferences from other organic aerosols not associated with diesel exhaust.*
- *Size selective (SS) sampling is based on the demonstration that submicrometer aerosols found in coalmines are primarily diesel in origin. The difference in the aerodynamic diameter particle size between combustion and mechanically generated aerosols can be used to separate diesel particulates from non-combustion aerosols. The SS sampler can be used in conjunction with the method for determining elemental carbon for quantification of diesel particulates in coalmines.*

Gravimetric-based methods (e.g. RCD, RCD in combination with SS sampling and SS sampling on its own) are inadequate at moderately low workplace concentrations because so little mass is collected that the weighing error becomes very large. RCD has further limitations because all combustible substances are measured, also those of non-diesel origin. Methods based on the NIOSH Method 5040 are much more sensitive to diesel particulate matter and exploit the

unique and reasonably strong correlation between EC and diesel particulate matter. Because of the presence of both organic and elemental carbon in coalmine dust, a sub-micron impactor can be used to separate the larger coal dust particles from the diesel particles (*NIOSH, 2002*). Size-selective equipment that collects the size fraction smaller than 1 µm for analysis is available on the market to distinguish between coal dust and diesel particulates. Combination of size selective sampling and determination of elemental carbon is therefore the preferred method to quantify diesel particulate concentrations in coalmines. Sampling in non-coalmines can be done without the use of a sub-micron impactor. Using the conventional method of sampling with cyclones to remove the excess of particles larger than 4 µm would be adequate.

4.2 Sampling and analysis methods for PAH

Sampling and analytical methods for the determination of PAHs are well established. Extraction can be done with Soxhlet methods or with accelerated solvent extraction (*DIONEX, 2002*), based on NIOSH Method 3545. Analysis is conducted using combined gas chromatography-mass spectroscopy (GC-MS) based on USEPA Method 8270. The complexity of PAHs in the environment is accountable for the difficulties associated with analysis of the samples. An analytical method that requires good chromatographic resolution and detection sensitivity is necessary to quantify selected compounds in such mixtures. Some of the PAHs, especially those with lower molecular weights, exist primarily in the vapour phase while PAHs with higher molecular weights exist primarily in the particle phase. A particulate filter and an adsorbent (XAD-2 or polyurethane foam (PUF)) cartridge combination is therefore used for the collection of PAH samples. Where distinction between vapour-phase and solid-phase PAHs is not of interest, it is adequate to use only the XAD-2 or PUF cartridges.

4.3 Demonstration of commercial instrumentation

The survey programme in pilot mines was designed to quantify diesel particulates according to the best sampling and analytical options. Analytical facilities of this nature are not available in South Africa, but only in a few places in the world at this time. The possibility of submitting samples for analysis at the UK Health and Safety Executive (HSE) was therefore considered. However, it was regarded to be in the interest of a longer-term strategy that the analytical expertise be established in South Africa to support exposure assessment programmes in the future. Collaboration with the UK Health and Safety Executive (HSE) in the method validation step was regarded as important, but it would not have been the best option to have all samples in this project analysed in the UK. On the other hand, it was not possible to purchase instruments for testing in this phase of the project. Through negotiation with two prominent international scientific instrument companies it was possible to arrange availability of two instruments for testing and demonstration in the project.

These are discussed in the sections below.

4.3.1 Horiba Mexa-1370PM Analyser

The Horiba Mexa-1370PM Analyser is a super-low-mass particulate matter analyser with high sensitivity. It can quantify soot (EC), the soluble organic fraction (SOF), sulphate, and total particulates on samples that are collected on quartz filters. The Horiba instrument is shown in Figure 4.3.1.1.



Figure 4.3.1.1: Horiba MEXA-1379PM elemental carbon analyser (Courtesy of the Engine Measurement Division, Horiba).

Diesel particulate matter is collected on a high purity quartz filter. The analytical process is illustrated in Figure 4.3.1.2. The filter is placed in the furnace section of the instrument. The first heating cycle is conducted under a stream of nitrogen. The volatile organic fraction is removed from the filter into the nitrogen stream and is carried to the next section where it is oxidised to carbon dioxide under a stream of oxygen. An infrared detector measures the amount of carbon dioxide and the instrument calculates the reading and reports the value as organic carbon. At the same time, sulphate is converted to sulphur dioxide and measured by a sulphur dioxide detector. After vaporisation of the volatile organic fraction and sulphate, oxygen is introduced into the furnace. The elemental carbon (soot) remaining on the filter is then oxidised to carbon dioxide and measured by the detector.

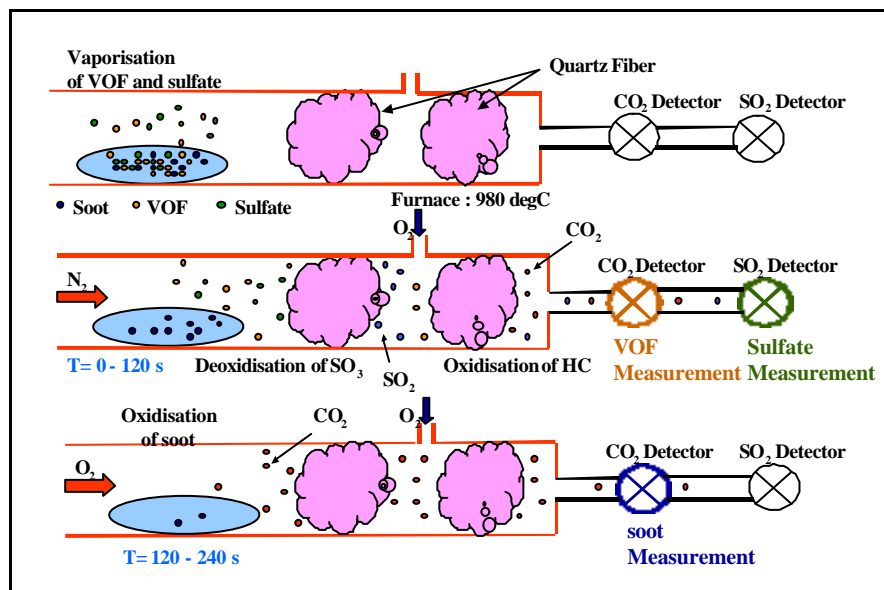

Figure 4.3.1.2: Illustration of the analytical process (Courtesy of the Engine Measurement Division, Horiba).

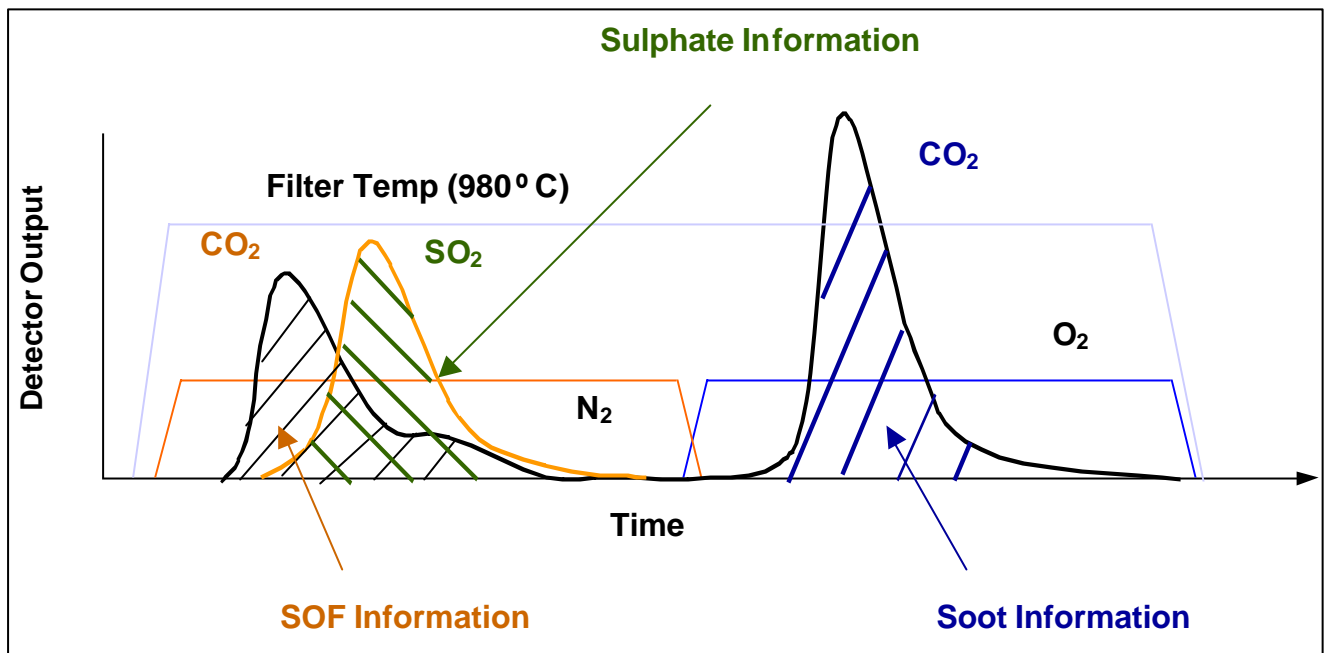

Figure 4.3.1.3: Illustration of the instrument readout of a filter analysis (Courtesy of the Engine Measurement Division, Horiba).

4.3.2 Rupprecht and Patashnick Series 5400 Ambient Carbon Particulate Monitor

The Rupprecht and Patashnick Series 5400 Ambient Carbon Particulate Monitor is shown in Figure 4.3.2.1.



Figure 4.3.2.1: The R&P Series 5400 Ambient Carbon Particulate Monitor in place for sampling and analysis in a goldmine.

The Series 5400 Ambient Carbon Particulate Monitor is an automatic speciation analyser of suspended particulate matter. Ambient air passes through a PM1 size selective inlet (to select particle smaller than 1 μm aerodynamic diameter) before entering the instrument. The monitor contains two cartridges located in temperature-regulated ovens to collect the sampled particulate matter. While one cartridge is being used for particle collection, the instrument performs its thermal carbon dioxide analysis on the previously collected particulate matter contained in the other collector. Using a direct thermal CO_2 technique, the instrument differentiates between organic and elemental carbon particulate matter by oxidising collected samples sequentially at an intermediate temperature followed by a high final burn temperature. The sampling and analysis diagram is illustrated in Figure 4.3.2.2.

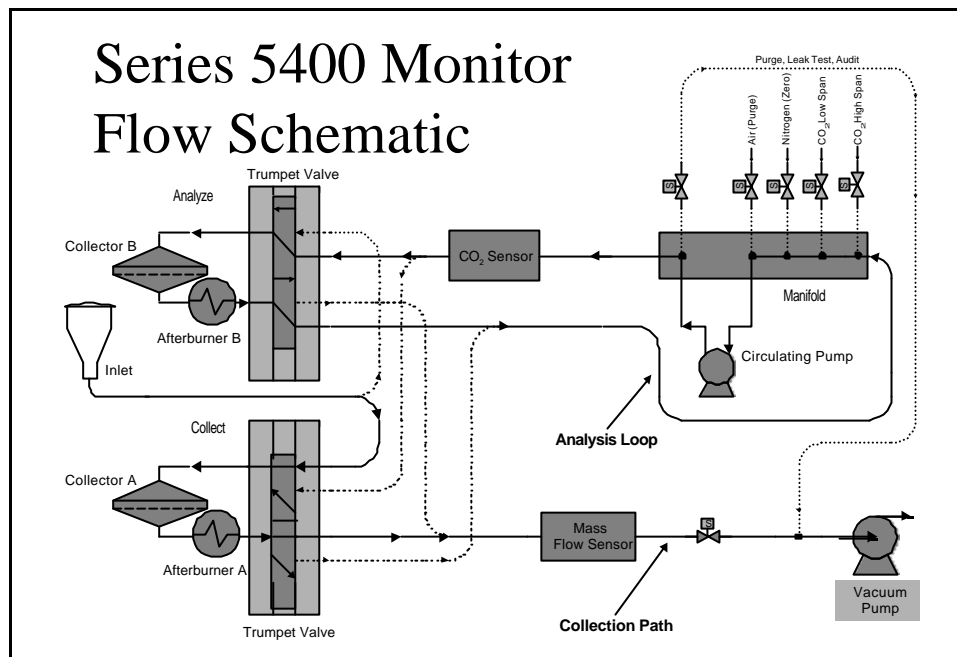

Figure 4.3.2.2: Flow diagram of the R&P Series 5400 Ambient Carbon Particulate Monitor (Courtesy of Rupprecht & Patashnick Co., Inc.).

4.3.3 Sampling cassettes

The SKC-DPM cassette with impactor is designed for sampling in atmospheres where it is necessary to differentiate diesel particulate matter from other respirable dust, such as coal dust, based on particle size. Loaded into each plastic cassette are a precision jewelled impactor, impaction substrate, a heat-treated quartz filter for sample collection, and a second quartz filter to be used as a blank. The impactor screens out respirable particles larger than 1.0 μm . Particles smaller than 1.0 μm , which represent diesel particulates, are collected on the filter. The cassette is illustrated in Figure 4.3.3.1.



Figure 4.3.3.1: SKC-DPM cassette with impactor.

The SKC-DPM cassette without impactor is designed to meet the specifications of the NIOSH 5040 method (NIOSH, 1998). The cassette is pre-loaded with a 37 mm heat-treated quartz filter and a cellulose support pad that has been prepared in a carbon-free humidity controlled clean room. The NIOSH 5040 method recommends the use of a cyclone as a pre-cleaner when sampling for DPM. The sampling arrangement is illustrated in Figure 4.3.3.2

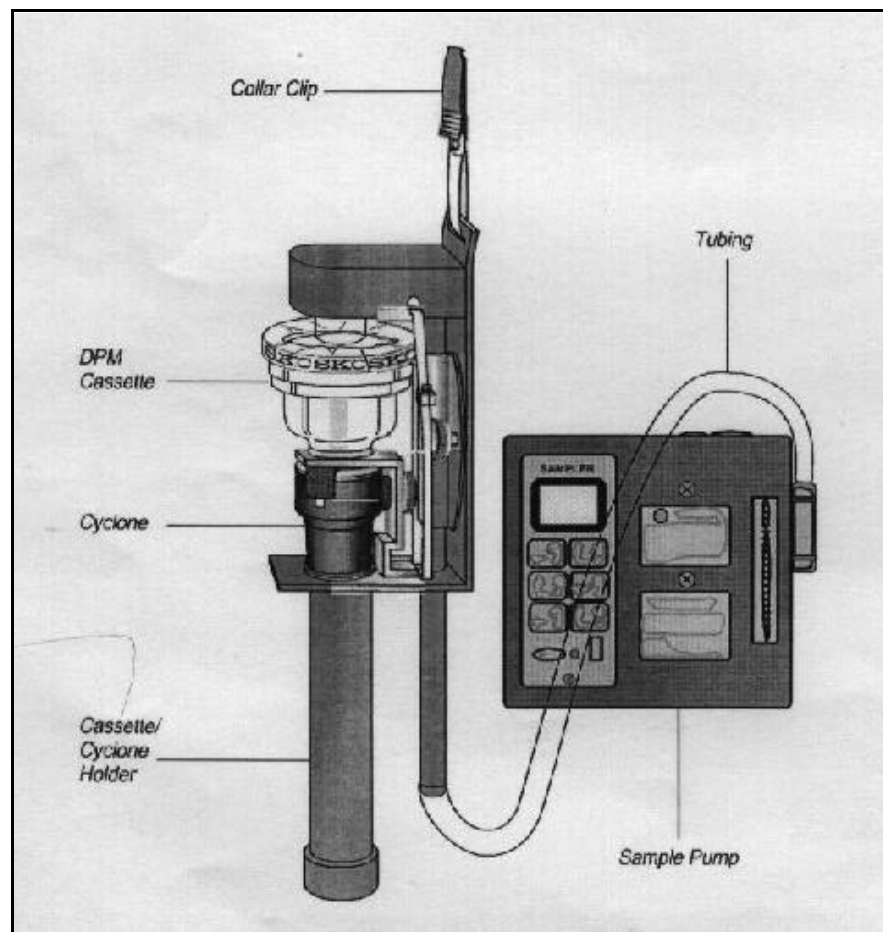

Figure 4.3.3.2: Personal sampling arrangement for diesel particulate matter according to NIOSH Method 5040.

5 Scope and design of field sampling

Two coalmines (collieries) and one hard rock goldmine were selected for the purpose of the evaluation of *in situ* measurements. The first coalmine was used for a pilot study using only the R&P Series 5400 Monitor. The R&P monitor was stationed at a selected underground location and automatic analysis of the air diesel particulates in that particular location was conducted on a 24-hour basis for 5 days.

In the second coalmine and the goldmine, the R&P monitor was installed and in addition, personal air sampling devices were allocated to employees engaged in underground duties. These samplers collected air samples from various areas where the study participants were performing their duties for that particular day. Allocation of personal air samplers was on a random basis with regard to the area of duty on that day. Most of the study participants were drivers of vehicles. As far as possible, personal samplers were allocated to equal numbers of the respective vehicle drivers. In the collieries these vehicles are typically buses, tractors and eimcos. Only one type of vehicle is used in the selected goldmine, namely locos.

On each sampling day, one stationary filter sample was taken at a position next to the R&P monitor, with the aim of comparing the direct-reading R&P measurements to results from the Horiba Mexa-1370PM Analyser.

Because the overall toxicity of diesel particulates is not associated only with the ultra fine particulates (elemental carbon), but also with adsorbed organic compounds such as the polynuclear aromatic hydrocarbons (PAHs), the survey also included the compound-specific characterisation of PAH concentrations. PAH samplers were therefore attached to the vehicle drivers and some were attached to the R&P monitor.

6 Materials and methods of the study

6.1 Sampling strategy

Samples in both of the collieries as well as in the goldmine were collected over a period of five days each. This period included safety induction, commissioning and calibration of the R&P monitor, and personal sampling where applicable. At the first colliery, two locations were selected for the R&P monitor and two-and-a-half days were allocated to each position.

The sampling strategy for personal exposure was aimed mainly at drivers of vehicles, as they were regarded as the employees that represented the high-risk group. These drivers were selected randomly, according to standard occupational hygiene practice. Personal sampling cassettes with sampling pumps were handed out to the participants at the beginning of each morning shift and collected again at the end of the shift.

6.2 Sampling methods

6.2.1 R&P Series 5400 Ambient Carbon Monitor

The R&P Series 5400 Ambient Carbon Monitor is a complete unit with a sampling inlet system equipped with a Series 5400 sampling pump. One- and three-hour samples were collected and the monitor was set on a 24-hour cycle. Periods of sample collection were, as far as possible, uninterrupted. An attempt was made to ensure that the sample intake position was at the same level as exhaust emissions from the vehicles. The monitor was allowed to warm up for 1 hour prior to the initiation of automatic sampling.

6.2.2 Personal sampling

To eliminate sampling of coal dust in the collieries, particulates larger than 1 µm were filtered out with the precision jewelled impactors fitted to the sampling trains. Two samples per day were collected on filters without the impactors to assess the effectiveness of size-selective sampling. Although only a few samples were collected to demonstrate this aspect, the amount of elemental carbon collected without the impactors clearly demonstrated significant interference of coal dust with the sampling for diesel particulates. (See Table 7.2.4.1)

Filters with size selective impactors were not necessary in the goldmine, but two samples per day were collected with impactors fitted on the cassette, as a comparison to filters with impactors. The results indicated that the impactors did not have a significant effect on the measurement of elemental carbon in the goldmine, where coal dust was not present.

Sampling trains consisted of Gilair personal sampling pumps and SKC-DPM cassettes, in an arrangement as illustrated in Figure 5.3.3.2 above. Flow rates were calibrated with a Gilair Gilibrator. Sampling pumps with the cassettes were attached to study participants in such a fashion that cyclones were in the breathing zones of the candidates. Cassettes were kept refrigerated at approximately 4 °C until analysed.

6.2.3 PAH samples

The PAH samples were collected with Gilair personal sampling pumps attached to the participants. The main participants were vehicle drivers. The pumps were calibrated to a constant flow of 0.5 litres per minute with an electronic soap-bubble Gilair Gilibrator. XAD-2 sampling tubes (Supelco Amberlite®) were used for sampling. The pump flow rate was checked post-sampling to ensure that the calibrated flow rate was maintained throughout the sampling period.

A maximum of three samples were collected per day over the five-day collection period. Two of the PAH samples were collected underground and one at the security gate or at the ventilation office aboveground. At the end of the sampling periods, the open ends of the XAD-2 glass tubes were closed with end caps and wrapped in tin foil. The sample tubes were packed in a suitable container lined with high-density foam rubber to prevent possible sample loss due to vibration. Ice sachets were placed in the container to keep the samples cool during transportation. In the analytical laboratory the samples were stored at 5°C until extraction. After extraction the samples were stored in a refrigerator at 5 °C under which conditions they would be stable for 28 days.

6.2.4 Summary of samples

A summary of the direct-reading samples registered with the R&P Series 5400 Ambient Carbon Monitor at the respective mines is given in Table 6.2.4.1 below.

Table 6.2.4.1
Summary of the direct-reading monitoring activities at the various mines.

	Colliery A	Colliery B	Goldmine A	Total
Total number of analyses scheduled	40	32	23	95
Analyses excluded because of unacceptable status codes	24	4	20	48
Number of acceptable analyses	16	28	3	47

A summary of the numbers of vehicle drivers participating in the personal sampling programme at the various mines and of the stationary samples taken with the Gilair personal sampling device is given in Table 6.2.4.2 below.

Samples taken at another goldmine and at two platinum mines were also analysed. These were sampled by industrial hygienist companies and submitted for analysis. Although not part of this SIMRAC project, the results have been included to provide an additional perspective of the exposure situation in mines. (See Table 9.1.)

Table 6.2.4.2
Summary of the number of samples taken with the Gilair personal sampling device at Colliery B and Goldmine A.

Vehicle type	Colliery B			Goldmine A			Total
	With impactor	Without impactor	PAH	With impactor	Without impactor	PAH	
Number of participating vehicle drivers							
Bus	6	1	2	0	0	0	9
Tractor	9	2	2	0	0	0	13
Eimco	4	2	5	0	0	0	11
Sweeper	1	0	0	0	0	0	1
Loco	0	0	0	3	17	8	28
Stationary samples							
R&P monitor position	5	0	1	1	5	4	16
Change room above ground	0	0	0	1	2	1	4
Security gate	2	0	0	0	0	0	2
VOHE above ground	3	0	0	0	0	0	3
Loco above ground	0	0	0	0	1	0	1
Total	30	5	10	5	25	13	88
Grand total	45			43			

VOHE: Ventilation and hygienist's office.

6.3 Analytical methods

6.3.1 Quantification of elemental carbon with the Horiba Mexa PM Analyser

The HORIBA MEXA 1370PM Super Low Mass Particulate Matter Analyser was used to determine the soluble organic fraction (SOF), soot (elemental carbon), sulphate, and total carbon on samples collected on quartz filters. Calibration was done with sulphur dioxide (SO₂) at 1 435 ppm and carbon dioxide (CO₂) at 7.4 mole per cent. Nitrogen gas (N₂) at 99.999 per cent purity and oxygen gas (O₂) at 99.995 per cent purity were used as carrier gases. Compressed air was used to activate the valves.

6.3.2 Direct-reading of elemental carbon with the R&P Series 5400 Ambient Carbon Monitor

After a one-hour warm-up period, the run settings that define the operation of the monitor during the collection and analysis phases of the monitor cycle were set according to manufacturer's instructions.

6.3.3 Quantification of polynuclear aromatic hydrocarbons

Extraction of XAD-2 resin was done with accelerated solvent extraction (ASE®) (Dionex, 2002) based on NIOSH Method 3545. Analysis of the selected heterocyclic PAHs was performed by GC-MS analysis based on NIOSH Method 8270. The range of PAHs is listed below.

- Anthracene
- Benz(a)anthracene
- Benz(b)fluoranthene
- Benz(k)fluoranthene
- Benz(j)fluoranthene
- Benzo(a)pyrene

- Benzo(e)pyrene
- Benzo(ghi)perylene
- Chrysene
- Cyclopentadienol(cd)pyrene
- Dibenz(a,h)anthracene
- Indenol(1,2,3-cd)pyrene
- Pyrene

6.4 Statistical methods

Statistical analyses were done with the STATA™ Version 7 software programme (©1984-2001, Stata Corporation, Texas, USA). All sample numbers of the individual study groups were relatively small (n less than 30) and non-parametric tests were therefore used throughout the statistical analyses. For comparison of two groups, the Wilcoxon signed-rank test was used for paired (related) samples and the Wilcoxon rank-sum (Mann-Whitney U) test for unpaired samples (samples that were not related). For these tests, the probability of obtaining significance by chance (the level of α) was set at 0.05.

For comparison of three or more groups, the Kruskal-Wallis one-way analysis of variance (ANOVA) was used to test the equality of populations. For this test, the software programme automatically adjusted the level of α according to the number of comparisons made. In cases where the Kruskal-Wallis one-way ANOVA indicated a statistically significant difference in means amongst the groups, the Bonferroni t method, also called Dunn's multiple-comparison procedure, was used to identify the specific groups with significantly different means. The Bonferroni t method increases the critical F value needed for the comparison to be declared significant. The amount of increase depends on the number of comparisons and the sample size (Dawson and Trapp, 2001).

The amount of elemental carbon sampled on personal air sampler filters was determined with two comparable methods, namely with the Horiba Mexa 370PM Analyser and with a combustion method with voltammetry detection by the UK Health and Safety Executive (HSE). The elemental carbon concentrations of paired samples analysed by these two methods were statistically compared using the Bland-Altman plot, from the Medcalc™ Version 6.00 software programme (©1993-2000, Frank Schoonjans, Broekstraat 52, 9030 Mariakerke, Belgium).

7 Analytical results for elemental carbon

7.1 Colliery A

7.1.1 Site conditions

The location for direct-reading measurements and the ambient conditions at the locations are described in Table 7.1.1.1 below. These data have not been used in interpretations in the current phase of the project, but have been listed for possible future reference when exposure control options will be considered.

Table 7.1.1.1
Conditions at the direct-reading sampling locations in Colliery A.

Description	Colliery A Shaft 1, Seam 4	
	1	2
Sampling position		
Description	Road A split 9	Road A split 62
Depth below surface	75 m	73 m
Distance from shaft	0.228 km	1.25 km
Volumetric ventilation rate	18.7 m ³ /sec	15.2 m ³ /sec
Air velocity at sampling positions	0.67 m/sec	0.56 m/sec
Air velocity mid road	n/a	0.23 m/sec
Barometric pressure	84.24 kPa	84.24 kPa
Temperature	18 °C	17 °C
Relative humidity	86 %	85 %

n/a: Not available.

7.1.2 Error messages and limitations of the R&P Series 5400 instrument

During the analysis phase the oven heats up to 750 °C and requires at least 10 A and 240 V electrical supply. If the AC voltage is too low, a status code X is displayed. Under these conditions, analysis results are inaccurate and are disregarded. This is a problem that occurred several times, which may place a limitation on the operation of the direct-reading instrument in mines with unstable power supplies.

7.1.3 Analysis results of direct-reading measurements

The direct-reading results at Colliery A are presented in Table 7.1.3.1 below. Samples coded with an error status have been excluded.

Table 7.1.3.1
Direct-reading sampling results at Colliery A

Sample no	Elemental carbon at position 1 (µg/m ³)	Elemental carbon at position 2 (µg/m ³)
1	27.3	
2	17.8	
3	5.4	
4	3.4	
5	2.2	
6	17.2	
7	26.3	
8	40.4	
9	36.0	
23	30.1	
24	12.4	
25	5.0	
26	4.5	
27	7.4	
28		69.8
29		45.6

The results indicate low concentrations of elemental carbon with very little variation over time.

7.2 Colliery B

7.2.1 Site conditions

The position of the direct-reading sampling instrument and the ambient conditions at the sampling location are summarised in Table 7.2.1 below. These data have not been used in interpretations in the current phase of the project, but have been listed for possible future reference when exposure control options will be considered.

***Table 7.2.1.1
Conditions at the direct-reading location in Colliery B.***

Description	Colliery B Hope shaft, Seam 2
Sampling position	P 600 split 120 (tractor road)
Depth of shaft	35-37 metre (vertical)
Distance from shaft	7.24 km
Volumetric ventilation rate	42.4 m ³ /s
Air velocity mid road	1.5 m/s
Air velocity at the sampling position	0.7 m/s
Barometric pressure	85.05 kPa
Temperature	DB 18°C; WB 16°C
Relative humidity	86.9%

DB: Dry bulb temperature.
WB: Wet bulb temperature.

7.2.2 Error messages and limitations of the R&P series 5400

During the analysis phase the oven heats up to 750 °C and requires at least 10 A and 240 V electrical supply. If the AC voltage is too low, a status code X is displayed. Under these conditions, analysis results are inaccurate and are disregarded. Similar to the situation in coalmine A, this problem occurred several times, which may place a limitation on the operation of the direct-reading instrument in mines with unstable power supplies.

7.2.3 Results of direct-reading measurements

The direct-reading results at Colliery B, determined with the R&P Series 5400 Monitor, are listed in Table 7.2.3.1 below. Samples with error status coding have been excluded. Position 1 refers to samples collected 2.7 m above the floor level, and position 2 at 1.8 m above the floor level. The second position was more appropriate for collecting emissions from the diesel vehicles because it was in line with the vehicle exhausts. This is clearly reflected in the higher levels of elemental carbon at position 2.

Variations in concentration may be expected over time, depending on mining activities and vehicle use. It was therefore not useful to calculate average values. Overall, the results clearly indicated low concentrations of elemental carbon at the locations where the R&P samples were collected.

Table 7.2.3.1
Direct-reading results at Colliery B.

Sample no	Elemental carbon at position 1 ($\mu\text{g}/\text{m}^3$)	Elemental carbon at position 2 ($\mu\text{g}/\text{m}^3$)
1	11.1	
2	11.7	
3	10.8	
4	10.4	
5	11.7	
6	10.8	
7	10.3	
8	10.0	
9	8.1	
10	6.8	
11	6.9	
12	8.0	
13	7.6	
14	10.0	
15		21.8
16		40.3
17		19.6
18		11.5
19		14.7
20		16.5
21		14.3
26		19.4
27		21.3
28		15.5
29		8.1
30		7.9
31		8.9
32		13.0

7.2.4 Personal sampling results

The personal sampling results at Colliery B, determined with the Horiba Mexa PM analyser, are presented in Table 7.2.4.1 below.

Table 7.2.4.1

Elemental carbon concentrations analysed with the Horiba Mexa PM analyser on quartz filters from personal samplers at Colliery B. All results are in $\mu\text{g}/\text{m}^3$.

With impactors			Without impactors	
Tractor <i>n</i> =7	Bus <i>n</i> =7	Eimco <i>n</i> =5	Ventilation office above ground <i>n</i> =5	Random personal samplers <i>n</i> =4
35	113	11	66	268
22	90	49	92	1096
7	582	100	961	1562
27	33	39	8	630
17	18	29	1281	
33	4			
78	25			

The personal samples showed that some of the bus drivers were exposed to higher levels of diesel particulates than drivers of tractors and eimcos. These samples were collected with size-selective impactors in the sampling trains. It is interesting to note that tractors and eimcos were equipped with emission control scrubbers, whereas buses were not. There may also be other reasons for the difference, but the various possibilities have not been investigated.

Results of measurements with and without impactors clearly demonstrated the interference of coal dust where size-selective sampling was not conducted at the coalmine.

7.3 Sampling at Goldmine A

7.3.1 Site conditions

The position of the direct-reading instrument and conditions at the sampling location are presented in Table 7.3.1.1 below. These data have not been used in interpretations in the current phase of the project, but have been listed for possible future reference when exposure control options will be considered.

Table 7.3.1.1

Conditions at the direct-reading location in Goldmine A.

Description	Level 39, end of section 31C
Position	Road A split 9
Depth below surface	3 184 m
Distance from shaft	0.235 km
Volumetric ventilation rate	22.4 m ³ /sec
Air velocity at sampling location	1.4 m/sec
Barometric pressure	116.0 kPa
Temperature	30.5 °C DB; 34 °C WB
Relative humidity	82.5 %

DB: Dry bulb temperature.

WB: Wet bulb temperature.

7.3.2 Error messages and limitations of the R&P Series 5400 measurements

Fewer direct-reading analyses were done at Goldmine A because an electrical power point was not available for several days. Once a connection was established, the electrical current was not stable and the monitor displayed status symbol “X”, indicating that the AC voltage supply had sometimes dropped to below the minimum requirements of the instrument. Under these conditions, analysis results were inaccurate and were disregarded. It appeared that conditions in the mine did not allow for a stable electricity supply, which in general would place a limitation on the use of the R&P instrument.

A status code “H” was also displayed at the Goldmine A sampling location, indicating that the CO₂ reading was too high and exceeded the calibration range. This occurred under conditions of heavy traffic and excessive particulate emissions, which exceeded the dynamic range of the instrument. Under these conditions analyses results were considered to be inaccurate and were disregarded.

7.3.3 Direct-reading results

The direct-reading sampling results at Goldmine A are listed in Table 7.3.3.1 below. Samples with error status coding were excluded.

***Table 7.3.3.1
Direct-reading results at Goldmine A.***

Sample no	Elemental carbon ($\mu\text{g}/\text{m}^3$)
6	32
8	29
14	36

7.3.4 Personal sampling results

The personal sampling results at Goldmine A, determined with the Horiba Mexa PM Analyser, are presented in Table 7.3.4.1 below.

Table 7.3.4.1

Elemental carbon concentrations analysed with the Horiba Mexa PM analyser on quartz filters from personal samplers at Goldmine A. All results are in $\mu\text{g}/\text{m}^3$.

Loco drivers (without impactors)	Ventilation office above ground (without impactors)	Random personal samplers with impactors
128	10	308
164	58	30
66	37	73
261		75
267		37
255		
254		
153		
305		
320		
153		
258		
619		
664		

Variations in exposure concentration may be expected between different vehicles, depending on vehicle condition and pattern of use. It was therefore not useful to calculate average values. Exposure concentrations of over $600 \mu\text{g}/\text{m}^3$ were observed in some cases, with several values falling in the range 200 to $300 \mu\text{g}/\text{m}^3$. Samples collected at the ventilation office illustrated background concentrations.

As expected, use of size-selective sampling did not appear to have a significant effect on the measured exposure levels, as reflected by the value of $308 \mu\text{g}/\text{m}^3$ recorded on a random sample. These were however a limited number of data points and paired samples without impactors were not available for statistical verification of differences.

7.4 Additional personal sampling at Goldmine B

The personal sampling results at Goldmine B, determined with the Horiba Mexa PM analyser, are presented in Table 7.4.1 below. Site conditions were not recorded.

Table 7.4.1

Elemental carbon concentrations analysed with the Horiba Mexa PM Analyser on quartz filters from personal samplers at Goldmine B. All results are in $\mu\text{g}/\text{m}^3$.

Personal samples on loco drivers
975
420
736
524
1176

The measured exposures were all very high, ranging up to over a $1\,000 \mu\text{g}/\text{m}^3$.

7.5 Additional personal sampling at Platinum Mine A

7.5.1 Site conditions

Conditions at the study area are listed in Table 7.5.1.1 below. These data have not been used in interpretations in the current phase of the project, but have been listed for possible future reference when exposure control options will be considered.

Table 7.5.1.1
Conditions at the sampling location in Platinum Mine A.

Description	
Depth below surface	120 m
Distance from shaft	0.235 km
Volumetric ventilation rate in main haulage	7.4 m ³ /sec
Air velocity at sampling location	0.75 m/sec
Barometric pressure	85.0 kPa
Temperature	29.3 °C DB; 30.7 °C WB
Relative humidity	82.5 %

DB: Dry bulb temperature.

WB: Wet bulb temperature.

7.5.2 Sampling results

Sampling results at Platinum Mine A, determined with the Horiba Mexa PM analyser, are presented in Table 7.5.2.1 below.

Table 7.5.2.1
Elemental carbon concentrations analysed with the Horiba Mexa PM analyser on quartz filters from personal samplers at Platinum Mine A. All results in µg/m³.

Samples taken at ventilation outlet
4466
4575
406
456

The samples were collected at the ventilation outlet and represent an idea of the accumulation of diesel particulate matter in the workplace air. If workers were exposed in areas close to the ventilation outlet, exposures would be very high.

7.6 Additional personal sampling at Platinum mine B

The personal sampling results at Platinum mine B, determined with the Horiba Mexa PM analyser, are given in Table 7.6.1 below. Site conditions were not recorded.

Table 7.6.1
Elemental carbon concentrations analysed with the Horiba Mexa PM analyser on quartz filters from personal samplers at Platinum mine B. All results are in µg/m³.

Samples taken at ventilation outlet
748.78
1435.83
477.14
1984.25

Similar to the survey conducted in Platinum Mine A, samples were collected at the ventilation outlet and represent an idea of the accumulation of diesel particulate matter in the workplace air. Should workers be exposed in areas close to the ventilation outlet, exposures would be very high.

7.7 Comparative Data

7.7.1 Horiba Mexa Analyser versus the UK HSE

Five pairs of personal samples were collected at the ventilation outlet of a mine. The collection method and the sample collection times were identical for the two samples in each pair. One sample of each pair was analysed with the Horiba Mexa analyser and the other sample was analysed by the Health and Safety Executive (HSE) in the UK. The results are presented in Table 7.7.1.1 below.

Table 7.7.1.1
Elemental carbon concentrations analysed with the Horiba Mexa PM analyser versus the HSE UK on quartz filters from personal samplers. All results are in $\mu\text{g}/\text{m}^3$.

Horiba			HSE		
Elemental Carbon (EC)	Organic Carbon (OC)	OC/EC ratio	Elemental Carbon (EC)	Organic Carbon (OC)	OC/EC ratio
614	7131	1.16	433	278	0.62
264	409	1.54	141	478	3.39
463	687	1.48	321	729	2.27
330	617	1.87	257	606	2.35
740	319	0.43	891	628	0.30

Results of statistical analyses are presented in Section 7.8 below.

7.7.2 Horiba Mexa analyser versus the R&P direct-reading monitor

Filter samples were collected at the same locations as where the R&P monitor was situated, and as far as possible within the same sampling periods. No corresponding R&P sample could be collected at Colliery B on the first day of sampling due to the late start of the R&P monitor and no R&P samples were collected at Goldmine A on the first two days due to the unavailability of an electrical power supply.

The elemental carbon concentrations of personal samples collected at Colliery B and the corresponding R&P monitor results are presented in Table 7.7.2.1 below and those for Goldmine A in Table 7.7.2.2 below.

Table 7.7.2.1
Elemental carbon concentrations of personal samples analysed with the Horiba Mexa PM analyser versus elemental carbon concentrations of samples analysed with the R&P Monitor at Colliery B. All results are in $\mu\text{g}/\text{m}^3$.

Day of the study	Horiba Mexa PM Analyser	R&P Monitor
1	71.9	No sample
2	33.9	11.7 (Sample inlet higher than personal sample)
3	12.1	11.5
4	17.0	14.3
5	8.9	8.1

Table 7.7.2.2

Elemental carbon concentrations of personal samples analysed with the Horiba Mexa PM Analyser versus elemental carbon concentrations of direct-reading samples analysed with the R&P Monitor at Goldmine A. All results are in $\mu\text{g}/\text{m}^3$.

Day of the study	Horiba Mexa PM Analyser	R&P Monitor
1	35.5	No sample
2	35.5	No sample
3	70.4	60.1
4	205.2	34.8 (Status error)
5	16.5	16.4

The agreement between the measurements is remarkable, except for the samples collected on day 4 at the goldmine ($205.2 \mu\text{g}/\text{m}^3$ measured with the Horiba instrument against the R&P value of $34.8 \mu\text{g}/\text{m}^3$). However, the R&P instrument displayed a status error for that sample, which indicated that the reading should not be taken into account.

7.8 Results of statistical analyses

Comparison of elemental carbon concentrations between drivers of tractors, buses and eimcos at Colliery B

The ambient elemental carbon concentrations, to which the drivers of tractors, buses and eimcos had been exposed, were compared using the Kruskal-Wallis one-way analysis of variance (ANOVA). There was not a statistically significant difference between the elemental carbon concentrations as sampled in the three driver groups ($P > 0.050$; $P = 0.5947$).

Comparison of R&P direct-reading results paired with Horiba results

The paired personal samples were sampled with an impactor at the same stationary site as the R&P at both Colliery B (Table 7.7.2.1) and Goldmine A (Table 7.2.2.2). The paired samples were compared by use of the Bland-Altman plot, as illustrated in Figure 7.8.1 below.

The Bland-Altman illustrates a mean difference of $2.9 \mu\text{g}/\text{m}^3$ between the two methods. This implies that, on average, the Horiba measurements were $2.9 \mu\text{g}/\text{m}^3$ higher compared to the respective paired samples analysed by the R&P instrument. It can be seen from the positions of the points on the plot that the Horiba and R&P results were consistently very close to each other, with most differences very close to $0 \mu\text{g}/\text{m}^3$. The plot indicates that the 95 per cent range for the differences between the two instruments was -5.4 to $11.2 \mu\text{g}/\text{m}^3$, which is acceptable.

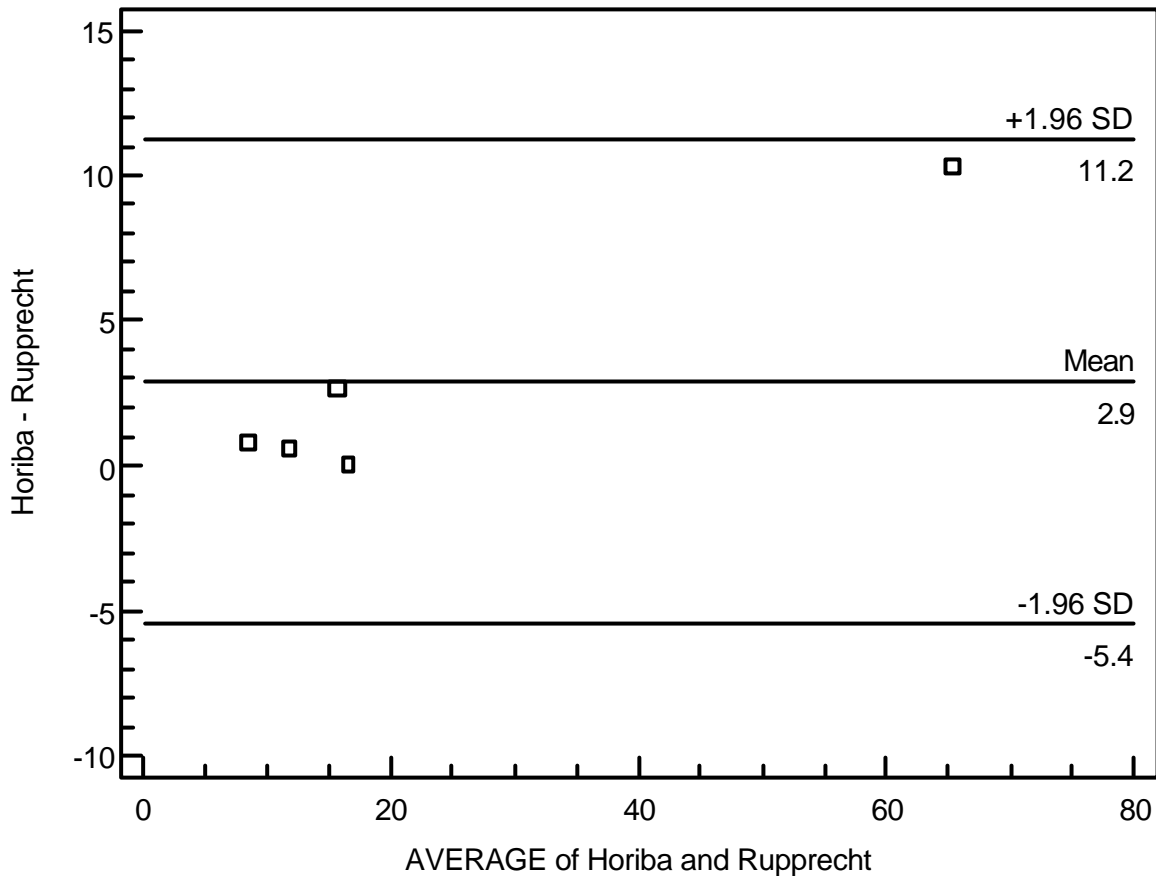

Figure 7.8.1: *Bland-Altman plot comparing elemental carbon measured with the Horiba Mexa PM analyser with direct reading results from the R&P instrument. All numbers are in $\mu\text{g}/\text{m}^3$.*

Comparison of R&P direct-reading results at various mines

The ambient elemental carbon concentrations determined *in situ* by the R&P at various positions in the three mines were compared between the different positions at the different mines using the Kruskal-Wallis one-way ANOVA. The results showed that there was a statistically significant difference between different mines at different positions ($P < 0.050$; $P = 0.0035$). The Bonferroni *t* method was subsequently used to identify specific positions and/or mines that differed from each other. The results are presented in Table 7.8.1 below.

Table 7.8.1
Bonferroni t-method results for different positions of R&P analyses in different mines.

Paired positions/mines	P-value
Colliery A position 1 vs Colliery A position 2	0.000 *
Colliery A pos 1 vs Colliery B pos A	0.434
Colliery A pos 2 vs Colliery B pos A	0.000 *
Colliery A pos 1 vs Colliery B pos B	1.000
Colliery A pos 2 vs Colliery B pos B	0.000 *
Colliery B pos A vs Colliery B pos B	0.466
Colliery A pos 1 vs Goldmine A	0.092
Colliery A pos 2 vs Goldmine A	0.049 *
Colliery B pos A vs Goldmine A	0.003 *
Colliery B pos B vs Goldmine A	0.101

* P-values less than 0.050 were considered significant.

Since only 2 samples were available at Colliery A position 2 and only 3 samples at Goldmine A, the resulting ANOVA model cannot be considered as robust, decreasing the statistical power of the study. It was therefore decided to repeat the ANOVA analysis using only the other groups, which had at least 13 samples in each group (Colliery A position 1: $n = 14$; Colliery B position A: $n = 14$; Colliery B pos B: $n = 13$).

The remaining groups were again compared using the Kruskal-Wallis one-way ANOVA and subsequently confirmed with the Bonferroni *t* method. Both the Kruskal-Wallis one-way ANOVA and the Bonferroni *t* method confirmed that the remaining groups did not differ statistically significantly from each other ($P > 0.050$ in both cases: $P = 0.0640$ for the Kruskal-Wallis one-way ANOVA and $P = 0.0657$ for the Bonferroni *t* method).

Comparison of paired personal samples analysed with the Horiba Mexa PM Analyser and by the HSE

The paired samples were compared by use of the Bland-Altman plot, as illustrated in Figure 7.8.1 below.

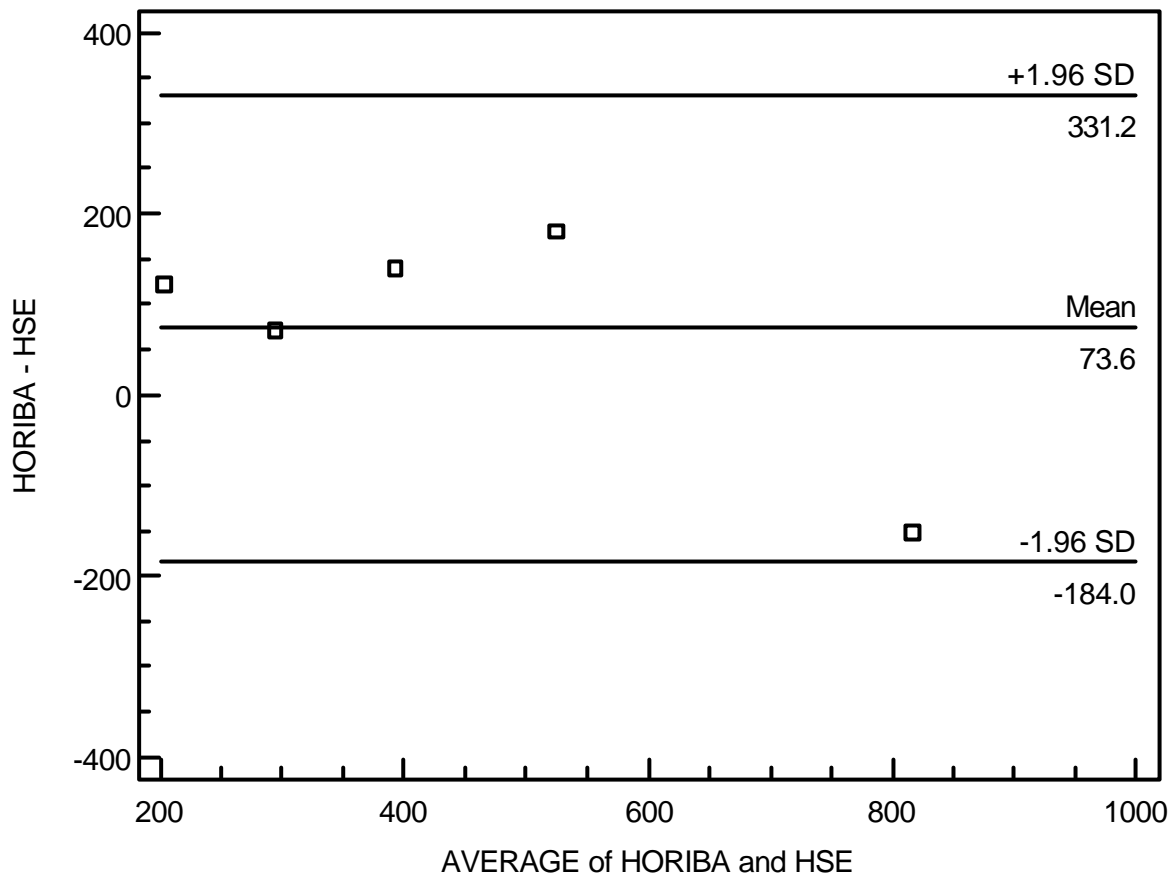

Figure 7.8.1: Bland-Altman plot comparing elemental carbon measured with the Horiba Mexa PM analyser with measurements by the HSE. All numbers are in $\mu\text{g}/\text{m}^3$.

The Bland-Altman illustrates a mean difference of $73.9 \mu\text{g}/\text{m}^3$ between the two methods. This implies that, on average, the Horiba measurements were $73.9 \mu\text{g}/\text{m}^3$ higher compared to the respective paired samples analysed by the UK HSE. It can be seen from the positions of the points on the plot that the Horiba results were consistently higher than the HSE results in the concentration range below approximately $700 \mu\text{g}/\text{m}^3$. In the case of the very high average concentration of around $825 \mu\text{g}/\text{m}^3$, the HSE result was higher than the Horiba result. The plot indicates that the 95 per cent range for the differences between the two measurements was -183.9 to $331.7 \mu\text{g}/\text{m}^3$.

It has to be taken into account that the measured concentrations were in $\mu\text{g}/\text{m}^3$, typically in the range of 1 part per million and lower. The differences between the Horiba results and the HSE analyses, as shown by the statistical interpretation, are not of big concern, except for the highest concentration pair (740 against $891 \mu\text{g}/\text{m}^3$ for the Horiba and HSE, respectively). At the high concentration end of the data points it may be possible that different instruments have different dynamic ranges, and calibration curves may not be linear at high concentrations. Overall, the differences between the two instruments are likely to be due to different calibration gas standards. These types of differences can be managed only through rigorous calibration and verification protocols, and not through inter-instrument comparisons.

Comparison of samples collected in the platinum mines

The Wilcoxon rank-sum (Mann-Whitney U) test for unpaired samples was used to compare the elemental carbon concentrations sampled by personal sampler in two platinum mines and subsequently analysed with the Horiba instrument. There was not a statistically significant

difference between the elemental carbon concentrations in the two mines ($P > 0.050$; $P = 1.0000$).

Comparison of personal samples taken in the goldmines

The Wilcoxon rank-sum (Mann-Whitney U) test for unpaired samples was used to compare the elemental carbon concentrations sampled by personal sampler in two goldmines and subsequently analysed with the Horiba instrument. There was a statistically significant difference between the elemental carbon concentrations in the two mines ($P < 0.050$; $P = 0.0041$), with a mean of 766.52 in Goldmine B, and a mean of 276.62 in Goldmine A.

8 Analytical data for polynuclear aromatic hydrocarbons(PAHs)

The PAH concentrations of personal samples collected at Colliery B and at Goldmine A are listed in Table 8.1 and 8.2 below.

Where guidelines for individual PAHs have been set, concentrations did not exceed the individual guideline concentrations (see Table 3.2.1). Total PAH concentrations on particular days were sometimes higher than the OSHA limit of 0.2 mg/m^3 for exposure to coal tar pitch volatiles.

Table 8.1
Concentrations of PAHs sampled at Colliery B (mg/m³).

Colliery B Compound	D 1/1	D 1/2	D 2/BI	D 2/1	D 2/2	D 3/1	D 3/2	D 4/1	D 4/2	D 5/1	D 5/2	D 5/3
Naphthalene	0.3	<0.1	<0.1	0.4	0.3	0.7	<0.1	0.3	<0.1	<0.1	0.1	<0.1
Acenaphthylene	<0.1	<0.1	<0.1	<0.1	<0.1	<0.1	<0.1	<0.1	<0.1	<0.1	<0.1	<0.1
Acenaphthene	<0.1	<0.1	<0.1	<0.1	<0.1	<0.1	<0.1	<0.1	<0.1	<0.1	<0.1	<0.1
Fluorene	<0.1	<0.1	<0.1	<0.1	<0.1	<0.1	<0.1	<0.1	<0.1	<0.1	<0.1	<0.1
Phenanthrene	<0.1	<0.1	<0.1	<0.1	<0.1	<0.1	<0.1	<0.1	<0.1	<0.1	<0.1	<0.1
Anthracene	<0.1	<0.1	<0.1	<0.1	<0.1	<0.1	<0.1	<0.1	<0.1	<0.1	<0.1	<0.1
Fluoranthene	<0.1	<0.1	<0.1	<0.1	<0.1	<0.1	<0.1	<0.1	<0.1	<0.1	<0.1	<0.1
Pyrene	<0.1	<0.1	<0.1	<0.1	<0.1	<0.1	<0.1	<0.1	<0.1	<0.1	<0.1	<0.1
Benzo(a)anthracene	<0.1	<0.1	<0.1	<0.1	<0.1	<0.1	<0.1	<0.1	<0.1	<0.1	<0.1	<0.1
Chrysene	<0.1	<0.1	<0.1	<0.1	<0.1	<0.1	<0.1	<0.1	<0.1	<0.1	<0.1	<0.1
Benzo(k)fluoranthene	<0.1	<0.1	<0.1	<0.1	<0.1	<0.1	<0.1	<0.1	<0.1	<0.1	<0.1	<0.1
Benzo(b)fluoranthene	<0.1	<0.1	<0.1	<0.1	<0.1	<0.1	<0.1	<0.1	<0.1	<0.1	<0.1	<0.1
Benzo(a)pyrene	<0.1	<0.1	<0.1	<0.1	<0.1	<0.1	<0.1	<0.1	<0.1	<0.1	<0.1	<0.1
Dibenz(a,h)anthracene	<0.1	<0.1	<0.1	<0.1	<0.1	<0.1	<0.1	<0.1	<0.1	<0.1	<0.1	<0.1
Benzo(ghi)perylene	<0.1	<0.1	<0.1	<0.1	<0.1	<0.1	<0.1	<0.1	<0.1	<0.1	<0.1	<0.1
Indeno(1,2,3.cd)pyrene	<0.1	<0.1	<0.1	<0.1	<0.1	<0.1	<0.1	<0.1	<0.1	<0.1	<0.1	<0.1
Total aromatics	0.3	0.0	0.0	0.4	0.3	0.7	0.0	0.3	0.0	0.0	0.1	0.0

Table 8.2
Concentrations of PAHs sampled at Goldmine A (mg/m³).

Goldmine A Compound	D 1/1	D 2/1	D 2/2	D 2/3	D 3/1	D 3/2	D 3/3	D 4/1	D 4/2	D 4/3	D 5/1	D 5/2a	D 5/2b	D 5/3
Naphthalene	<0.1	<0.1	<0.1	<0.1	<0.1	<0.1	<0.1	0.2	<0.1	<0.1	0.1	0.4	0.2	<0.1
Acenaphthylene	<0.1	<0.1	<0.1	<0.1	<0.1	<0.1	<0.1	<0.1	<0.1	<0.1	<0.1	<0.1	<0.1	<0.1
Acenaphthene	<0.1	<0.1	<0.1	<0.1	<0.1	<0.1	<0.1	<0.1	<0.1	<0.1	<0.1	<0.1	<0.1	<0.1
Fluorene	<0.1	<0.1	<0.1	<0.1	<0.1	<0.1	<0.1	<0.1	<0.1	<0.1	<0.1	<0.1	<0.1	<0.1
Phenanthrene	<0.1	<0.1	<0.1	<0.1	<0.1	<0.1	<0.1	<0.1	<0.1	<0.1	<0.1	<0.1	<0.1	<0.1
Anthracene	<0.1	<0.1	<0.1	<0.1	<0.1	<0.1	<0.1	<0.1	<0.1	<0.1	<0.1	<0.1	<0.1	<0.1
Fluoranthene	<0.1	<0.1	<0.1	<0.1	<0.1	<0.1	<0.1	<0.1	<0.1	<0.1	<0.1	<0.1	<0.1	<0.1
Pyrene	<0.1	<0.1	<0.1	<0.1	<0.1	<0.1	<0.1	<0.1	<0.1	<0.1	<0.1	<0.1	<0.1	<0.1
Benzo(a)anthracene	<0.1	<0.1	<0.1	<0.1	<0.1	<0.1	<0.1	<0.1	<0.1	<0.1	<0.1	<0.1	<0.1	<0.1
Chrysene	<0.1	<0.1	<0.1	<0.1	<0.1	<0.1	<0.1	<0.1	<0.1	<0.1	<0.1	<0.1	<0.1	<0.1
Benzo(k)fluoranthene	<0.1	<0.1	<0.1	<0.1	<0.1	<0.1	<0.1	<0.1	<0.1	<0.1	<0.1	<0.1	<0.1	<0.1
Benzo(b)fluoranthene	<0.1	<0.1	<0.1	<0.1	<0.1	<0.1	<0.1	<0.1	<0.1	<0.1	<0.1	<0.1	<0.1	<0.1
Benzo(a)pyrene	<0.1	<0.1	<0.1	<0.1	<0.1	<0.1	<0.1	<0.1	<0.1	<0.1	<0.1	<0.1	<0.1	<0.1
Dibenz(a,h)anthracene	<0.1	<0.1	<0.1	<0.1	<0.1	<0.1	<0.1	<0.1	<0.1	<0.1	<0.1	<0.1	<0.1	<0.1
Benzo(ghi)perylene	<0.1	<0.1	<0.1	<0.1	<0.1	<0.1	<0.1	<0.1	<0.1	<0.1	<0.1	<0.1	<0.1	<0.1
Indeno(1,2,3.cd)pyrene	<0.1	<0.1	<0.1	<0.1	<0.1	<0.1	<0.1	<0.1	<0.1	<0.1	<0.1	<0.1	<0.1	<0.1
Total aromatics	0.0	0.0	0.0	0.0	0.0	0.0	0.5	0.2	0.0	0.0	0.0	0.4	0.2	0.0

9 Discussion

When this SIMRAC project was initiated, the primary concern about diesel particulates in South African mines was that levels of exposure had never been quantified properly. Methods used in this endeavour produced results that were not reproducible, and whatever was measured could not be unambiguously related to diesel particulates. Therefore, the level of health risk to workers associated with exposure to diesel particulates was not known and could therefore not be managed effectively.

A primary objective in this study has been to identify the most appropriate sampling and analytical methods and to validate the procedures. Occupational exposure surveys in selected mines were integrated with this assessment process, to establish levels of exposure to diesel particulates.

In addition to this problem of quantification of exposure to particulates, there have also been concerns about potential exposure to polynuclear aromatic hydrocarbons (PAHs), which are common products of incomplete combustion and are known to adsorb readily onto a carbon substrate. The extent to which workers are exposed to PAHs adsorbed onto diesel particulates was not known.

Assessment of sampling and analysis methods that are currently in use in other parts of the world to quantify exposure to diesel particulates was identified as an essential step early in the study. The automotive industry generally uses a gravimetric method to quantify particulate emissions. However, it is difficult to quantify particulate emissions at levels in workplace air using a conventional gravimetric balance because the amount of particulates collected on filter samples for assessment of occupational exposure is very small. A primary objective in this study has been to identify the most appropriate sampling and analytical methods and to validate the procedures. Occupational exposure surveys in selected mines were integrated with this assessment process, to establish current levels of exposure to diesel particulates. The primary outputs of the study were therefore to establish an appropriate sampling and analytical technique and to assess current levels of exposure to diesel particulates in South African mines. Based on these findings, recommendations were to be made with regard to the need for the implementation of exposure control measures.

Three candidate mines were identified for testing of the sampling and analytical techniques. A pilot study was conducted in a coalmine, after which more comprehensive studies for quantification of exposure to diesel particulates and PAHs were done in one coalmine and one hard rock goldmine. Some measurements in another goldmine and in two platinum mines were later added to the programme.

Three types of methods were used to determine diesel particulate matter:

- A Rupprecht and Patashnick (R&P) Series 5400 Ambient Carbon Particulate Monitor that has the capability of direct sampling was used for quantification of elemental carbon associated with diesel particulate matter in ambient air.
- A laboratory-based Horiba Mexa 1370PM Super Low Mass PM Analyser was used to analyse diesel particulate matter captured on filters fitted to personal samplers of the type most commonly used to collect dust and other particulate matter in mines.
- A size selective sampler was used to differentiate between elemental carbon associated with diesel emissions and carbon particles from other sources, e.g. coal dust as present in coalmines.

Exposure to PAHs was shown to be insignificant. The investigation confirmed that determination of elemental carbon was the preferred method for quantification of exposure to diesel particulate emissions. It was clear from the results of personal sampling using the Horiba

Mexa 1370PM instrument for quantification that exposure in some of the mines exceeded the international guidelines significantly. Results of the study are summarised in Table 9.1 below.

Table 9.1
Compliance of mean concentrations of elemental carbon originating from diesel particulate matter, measured in the various mines, to selected international occupational exposure guidelines for elemental carbon.

South African Mine	Sampling method	Mean EC (mg/m ³)	Highest (mg/ m ³)
Colliery A position 1	Direct-reading	0.0168	0.0404*
Colliery A position 2	Direct-reading	0.0577*	0.0698*
Colliery B position 1	Direct-reading	0.0096	0.0117
Colliery B position 2	Direct-reading	0.0169	0.0403*
Colliery B tractor	Personal	0.0319*	0.0788*
Colliery B bus	Personal	0.1240*	0.5826**
Colliery B eimco	Personal	0.0460*	0.1001*
Goldmine A	Direct-reading	0.0328*	0.0365*
Goldmine A loco	Personal	0.0276*	0.6647**
Goldmine B loco	Personal	0.7665**	1.1761**
Platinum mine A (ventilation)	Area	2.4763**	4.5750**
Platinum mine B (ventilation)	Area	1.1615**	1.9840**
American Conference of Governmental Industrial Hygienists (ACGIH)		0.02 mg/m³	
US National Institute for Occupational Safety and Health (NIOSH)		0.16 mg/m³	

*: Concentration exceeded the ACGIH guideline.

** : Concentration exceeded both the ACGIH guideline and the NIOSH limit.

The mean elemental carbon concentrations at most sampling sites in most mines exceeded at least the ACGIH guideline, and some also exceeded the less strict guideline of NIOSH. A few concentrations were at least 10 times higher than the NIOSH limit. These comparisons clearly indicate the need for and the relevance of proposed regulation of diesel exhaust emissions.

A wide range of elemental carbon concentrations is evident in the South African mines. The factors contributing to these differences could probably include densities of underground diesel powered vehicle use, variations in the types of diesel powered vehicles used, underground ventilation practices, and the maintenance of vehicles or the lack thereof.

The validity of the Horiba measurements was confirmed by comparison of duplicate samples with analyses conducted by the Health and Safety Executive (HSE) in the UK. Furthermore, good agreement in readings was obtained between the Horiba instrument and the R&P direct-reading analyser, which provided additional confidence in the analyses. The study has therefore succeeded in establishing a reliable sampling and analytical method, based on the determination of elemental carbon, for quantifying occupational exposure to diesel particulate matter in mines. Size-selective sampling makes it possible to quantify exposure in the presence of coal dust in coalmines.

For the first time it has now been shown that exposure to diesel particulates in some of the South African mines are high, at such levels that health effects associated with these emissions may occur. These findings indicate the need for the assessment and possible introduction of measures to reduce emissions and exposure, and the requirement for introducing regulations for the control of exposure to diesel exhaust emissions in South African mines.

10 References

Collins, J. F., Brown, J. P. & Dawson, S. V. 1991. Risk Assessment for Benzo[a]pyrene. *Regulatory Toxicology and Pharmacology*, 13:170-184.

Dawson, B. & Trapp, R.G. 2001. *Basic and Clinical Biostatistics, 3rd Edition*. New York: Lange Medical Books/McGraw-Hill, p 170.

DEEP. 2001. (Diesel emissions evaluation programme), Sampling for diesel particulate matters in mines, CANMET: Mining and mineral science laboratories report (MMSL) 01-052

Dionex. 2002. Use of accelerated solvent extraction (ASE®) for cleaning and elution of XAD resin. Application note 347, Salt Lake City, UT, USA: Dionex Corporation.

Editorial 1999. Is diesel exhaust a cause for increasing allergies? *Clinical and experimental Allergies*, 29:4-8.

Fujieda, S., DiazSanchez, D. & Saxon, A. 1998. Combined nasal challenge with diesel exhaust particle and allergen induces in vivo IgE iso-type switching. *American Journal of Respiratory Cellular and Molecular Biology*, 19:507-512.

Gavett, S.H., Kelly, M.M., Madison, S.L. & Dreher, K.L. 1998. Fine ambient air particulate matter increases lavage eosinophil numbers and IL-4 in allergic mice. *American Journal of Respiratory Critical Care Medicine*, 157:A881.

Guillemin, M., Cachier, H., Chini, C., Dabill, D., Dahmann, D., Diebold, F., Fisher, A., Fricke, H., Groves, J.A., Hebisch, R., Houpillart, M., Israel, G., Mattenklott, M., Moldenhauer, W., Sandino, J.P., Schlums, C. Sutter, E. & Tucek, E. 1997. International round robin tests on the measurement of carbon in diesel exhaust particulates. *International Archives of Occupational and Environmental Health*, 70:161-172.

IARC. 2002. Monographs Series, Volumes 1 – 74. *Overall Evaluations of Carcinogenicity to Humans*. International Association for Research on Cancer. <http://193.51.164.11/monoeval/crthall.html>.

Murphy, S.A.M., BeruBe, K.A. & Richards R.J. 1999. Bioreactivity of carbon black and diesel exhaust particles to primary clara and type II epithelial cell cultures. *Occupational and Environmental Medicine*, 56:813-819.

Nagi, A., Kakuta, Y. & Ozawa, Y. 1996. Alveolar destruction in guinea pigs chronically exposed to diesel engine exhaust. A light microscopic and electron microscopic morphometry study. *American Journal of Respiratory Critical Care Medicine*, 153:724-730.

NIOSH. 1977. National Institute for Occupational Safety and Health. Criteria for a Recommended Standard - Occupational Exposure to Coal Tar Products. DHEW (NIOSH) Publication No.78 - 107. Cincinnati, OH: Department of Health, Education, and Welfare.

NIOSH. 1988. Carcinogenic effects of exposure to diesel exhaust. DHHS (NIOSH) Publication No 88-116. U.S. Department of Health and Human Services

NIOSH. 1998. Elemental carbon (diesel particulate): Method 5040. *In: NIOSH Manual of Analytical Methods (NMAM), 4th Edition, Issue 2, January 1998*. U.S. Department of Health and Human Services.

- NIOSH. 2002.** Review of Technology Available to the Underground Mining Industry for Control of Diesel Emissions. U.S. Department of Health and Human Services.
- NTP. 2002.** Report on Carcinogens, Tenth Edition; U.S. Department of Health and Human Services, Public Health Service, National Toxicology Program, December 2002.
- OSHA. 1978.** Occupational Safety and Health Administration. *Occupational Health Guideline for Coal Tar Pitch Volatiles*. Washington, DC: U.S. Department of Labour.
- Parnia, S.M., Frew, D. & Antony, J.M.D. 2001.** Is diesel the cause for the increase in allergic disease? *Annals of Allergy, Asthma and Immunology, 87(Supplement 3):18-23*.
- Rudell, B., Sandstrom, T., Stjernberg, N. & Kolmodin-Heldman, B. 1990.** Controlled diesel exhaust exposure in an exposure chamber: pulmonary effects investigated with bronchoalveolar lavage. *Journal of Aerosol Science, 21:5411-5414*.
- Salvi, S. & Holgate, S.T. 1999.** Mechanisms of particulate matter toxicity. *Clinical and Experimental Allergy, 29:1187-1194*.
- Suzuki, T. Kanoh, T. Ishimori, M. Ikeda, S. Ohkuni, H. 1996.** Adjuvant activity of DEP in production of anti IgE and anti IgG, antibodies to mite allergen in mice. *Journal of Clinical and Laboratory Immunology, 48:187-199*.
- Takenaka, M., Shibasaki, M., Tajima, K. 1995.** *Relation between frequency of asthma and IgE antibody levels against dermatophagoides farinae and total serum IgE levels*. *Journal of allergy and clinical immunology, 82(1): 86-94*.
- USEPA. 1993.** *Automobile Emissions: An Overview*. USEPA Office of Mobile Sources, January 1993.
- Wahlin, P., Palmgren, F. & Van Dingenen, R. 2001.** Experimental studies of ultra fine particles in streets and the relationship to traffic. *Atmospheric Environment, 35 (Supplement 1):563-569*.
- Watts, W. F. & Ramachandran, G. 2000.** Diesel Particulate Matter Sampling Methods: Statistical Comparison. Final Report Submitted to the Diesel Emission Evaluation Program.